



Rollix
VANS

HONDA ODYSSEY MINIVAN

SERVICE MANUAL



2011 - 2016

Service: (800) 956-6668
Local: (952) 890-7851
Fax: (952) 808-2775

Your Life. Your Ride.[™]
6591 W. Hwy 13
Savage, MN 55378
www.rollixvans.com



HONDA ODYSSEY MINIVAN 2011 - 2016

SERVICE MANUAL



Important Item Information and Locations 1

Battery Information - Draw Test Procedure7

Sliding Door Troubleshooting 10

Sliding Door Modifications 11

Exhaust System and Rear End..... 13

Ground Effects & Van Dimensions 14

Fuel System 15

Interior 19

Rear Suspension22

Front Suspension23

Front Cradle Drop.....24

Kneeler Trouble Shooting.....25

Kneeler Replacement Parts.....26

Kneeler Removal.....27

One Touch System Troubleshooting29

One Touch System Overview30

One Touch System - v8.0 Basic Interface32

One Touch System - v8.0 Advanced Interface - Setup.....33

One Touch System - v8.0 Advanced Interface - Debugger34

One Touch System - v8.0 Error Codes36





One Touch System - Relay Board Troubleshooting..... 42

Ramp Troubleshooting 43

Ramp Replacement Parts44

ITF Ramp Motor Removal.....45

Rear Heat & Air 47

Remote System Troubleshooting 48

Remote System-Location & Wiring.....49

Power Seat Wiring.....51

Seat ECU Overview69

Seat ECU Troubleshooting 72

Wiring Diagram - OTC System 77

SRS Component Location Index..... 85

Fuse Relay Boxes & Ground Location.....88

Maintenance Information 89

Warranty 90

Acronyms

- ASM.....Assembly
- DPMS.....Driver Position Memory System
- ECU.....Electronic Control Unit
- HSM.....Heated Seat Module
- ITF.....In The Floor
- LED.....Light Emitting Diode
- OEM.....Original Equipment Manufacturer
- OTC.....One Touch Controller
- SRS.....Supplemental Restraint System



Important Item Information and Locations



OEM Main Wire Harness
(Floor Along Driver Side)
(Ceiling Along Passenger side)

Rollx Vans Main Wire Harness
(Ceiling Along Passenger's Side)

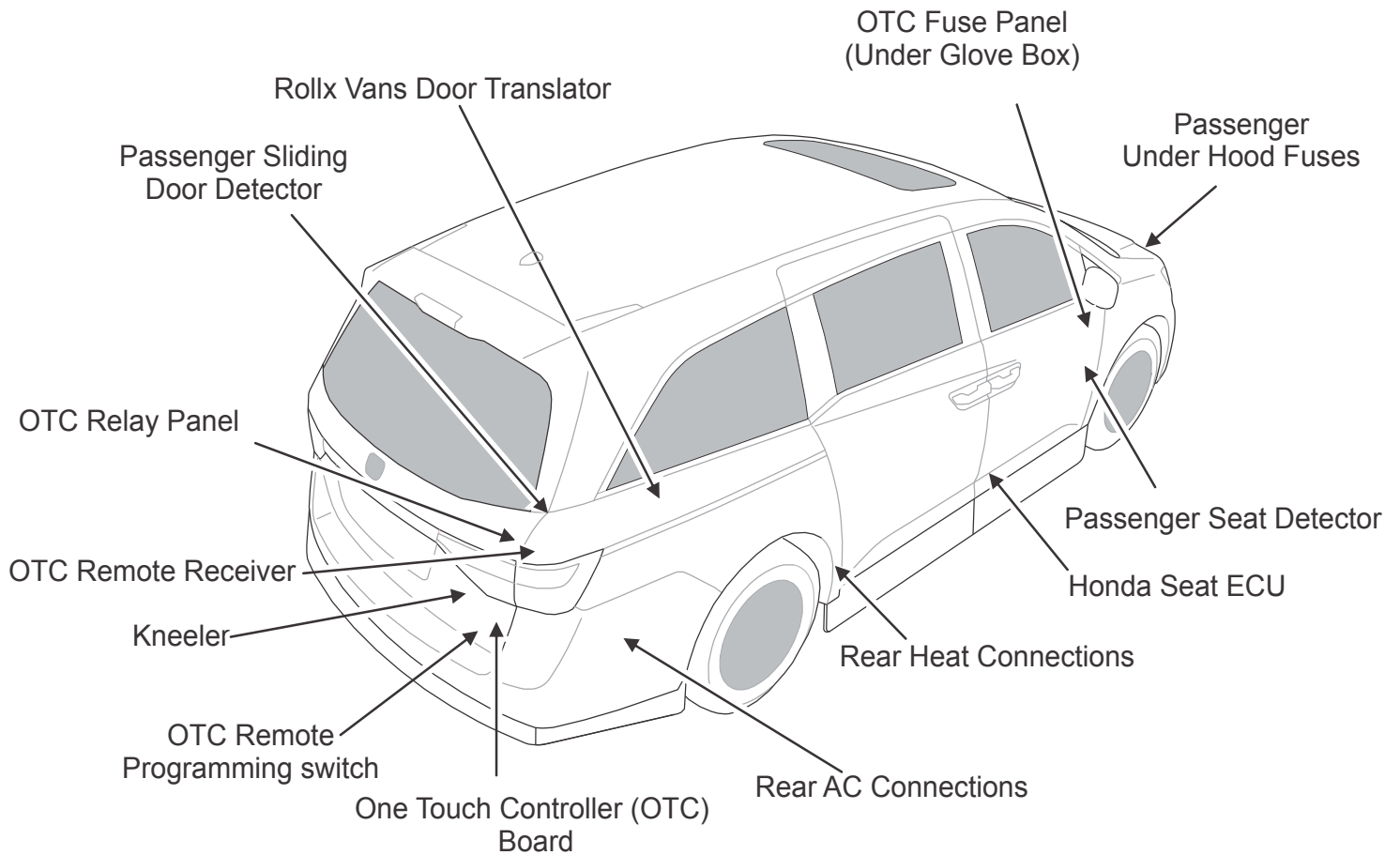
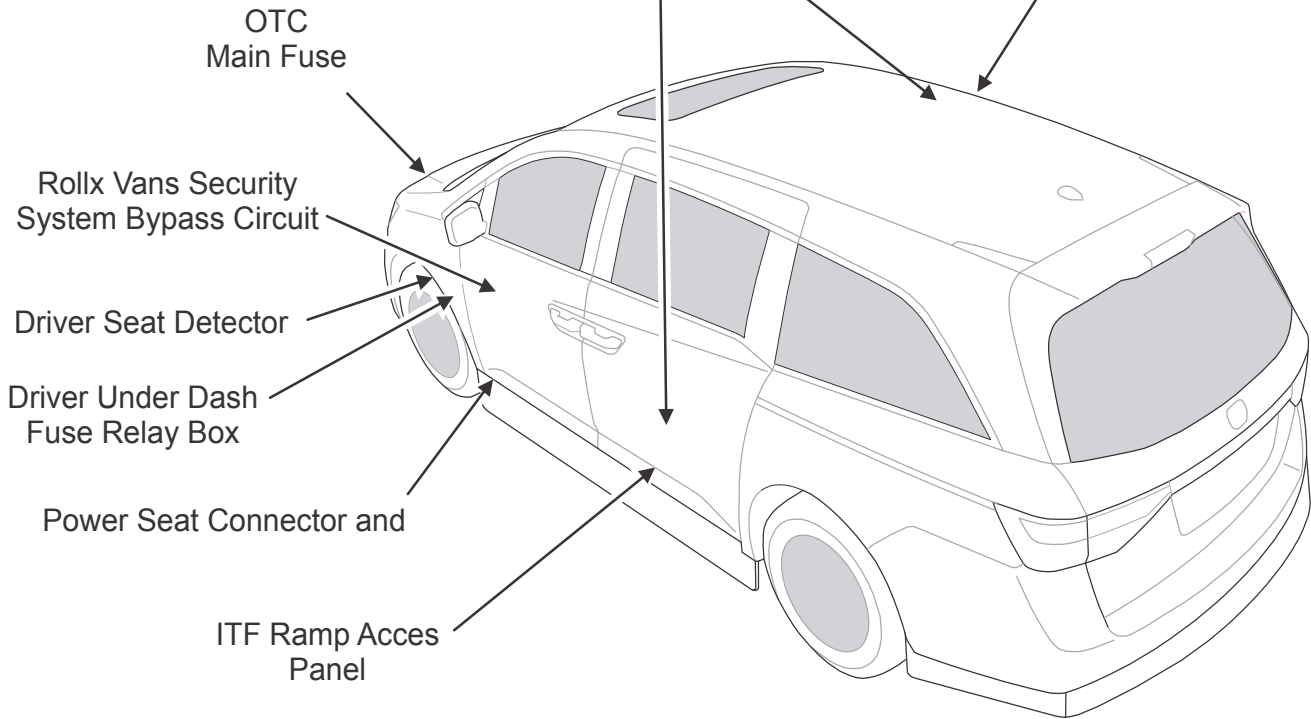

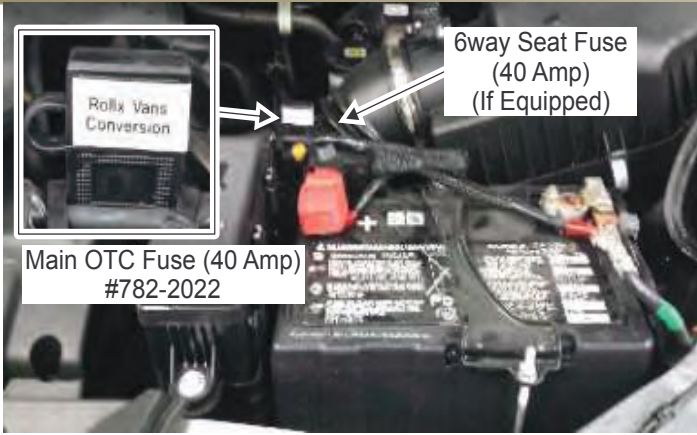

Main Fuse (Engine Compartment)

The Main OTC Fuse (40 amp) is used to power all components except the motors on a Transfer Seat. It can be used to isolate the Rollx Vans electrical system from the OEM system.



OTC Remote Receiver (Behind Rear Passenger Quarter Panel Above OTC Relay Board)

The Remote Receiver operates the OTC system only when the button on a transmitter is pressed.

More information can be found in the Remote System section.

It is powered through a 5 amp fuse in the fuse panel located under the passenger's side glove box.

2011-2013 Location



Passenger Sliding Door Detector

(Behind Rear Passenger Quarter Panel Below OTC Relay Board)

The Door Detector counts the pulses sent from the OEM door motor to determine when the door is all the way open. Its function to the OTC system is similar to a Door Open Limit Switch.

2014-2016 Location



It is powered through a 1 amp fuse in the fuse panel located under the passenger's side glove box.

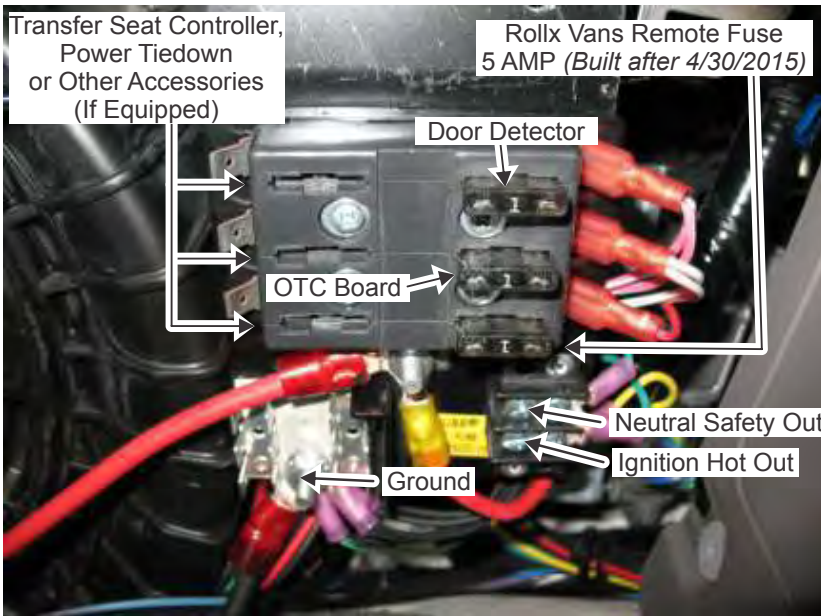

OTC Fuse Panel #46201 - 1 Amp Fuse (Under Glove Box)

Any Rollx Vans component besides a Transfer Seat Motor obtains its 12v power through this fuse panel. The fuse panel is powered from the main vehicle battery through a 40 amp fuse that is located near the battery. The fuse panel also has quick connections for Ignition Hot and Neutral Safety. Items powered through this location include:

Rollx Vans Standard Items:

- Remote (5 amp fuse)
- Door Detector (1 amp fuse)
- OTC Board (1 amp)
- OTC Relay Board (Direct)

Accessories

- Transfer Seat Control Board
- Power Tiedown
- Web Tech

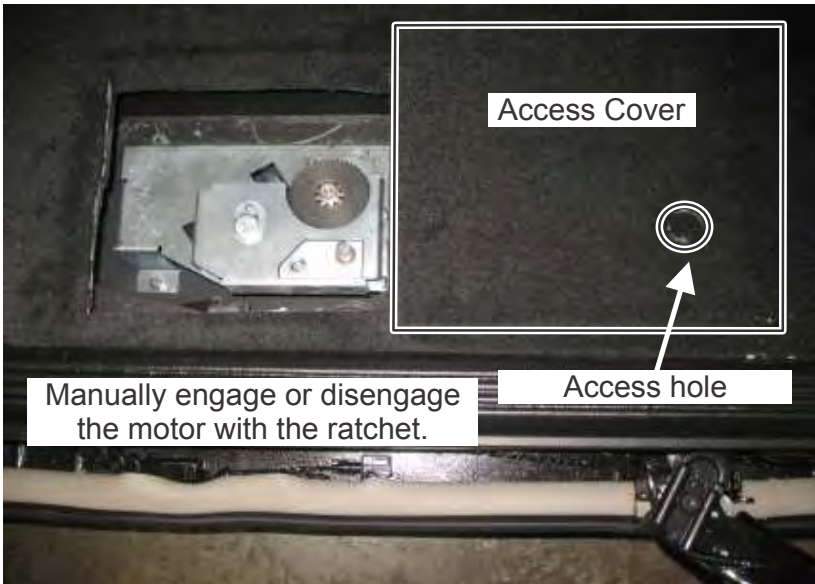

ITF Ramp Motor Access Plate (Behind Driver Seat)

The ramp motor, activator and limit switches can be accessed by removing this plate.

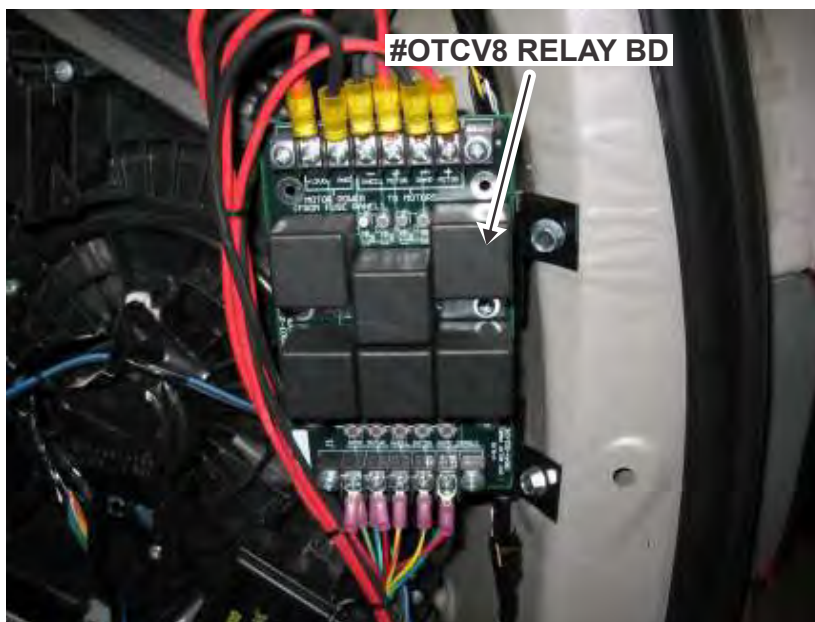

OTC Relay Board (Behind Rear Passenger Quarter Panel)

The Relay Board is controlled by the One Touch Control Board and sends power and ground to the ramp and kneel motors.

See OTC Relay Board Troubleshooting for more information.



Important Item Information and Locations

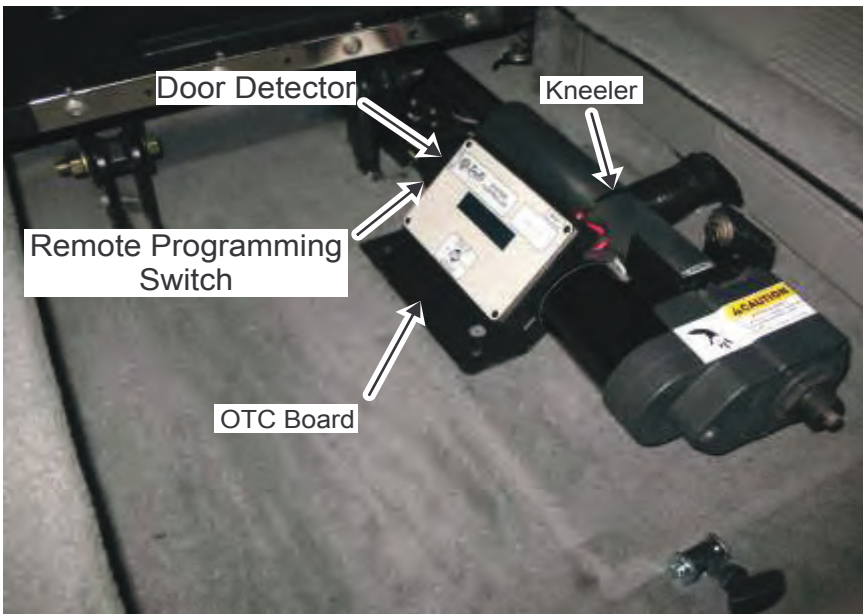

Kneeler, One Touch Controller Board, Door Detector, Remote Programming Switch: (Right rear of van below tire cover)

The **Kneeler** is an actuator that is connected to the rear axle on the passengers side of the van. Its function is to pull the van closer to the ground so that there is less of an incline on the ramp.

The **One Touch Controller Board** is the main controller which operates the functions of the passenger sliding door, the ramp and the kneeler.

The **Door Detector** Is a device we use to monitor the passenger sliding door status. Open or Closed.

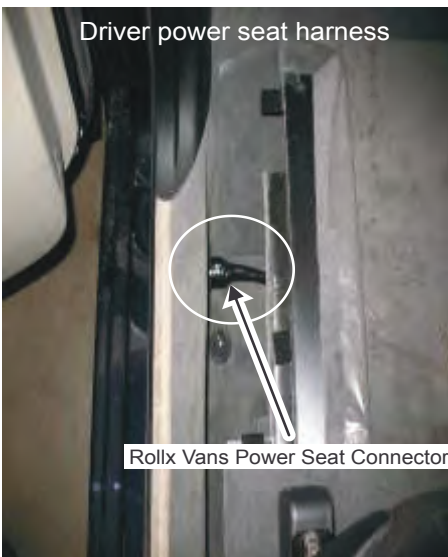

Driver power seat harness

Rollx Vans Power Seat Connector



Passenger power seat harness

Rollx Vans Power Seat Connector

Power Seat Connector (Lower front corners of the van)

Rollx Vans installs a **Power Seat Connector** to allow for quick removal of front seats. The OEM seat gets its power, ground, and heat functions through this connector.

More information can be found in the Power Seat section.

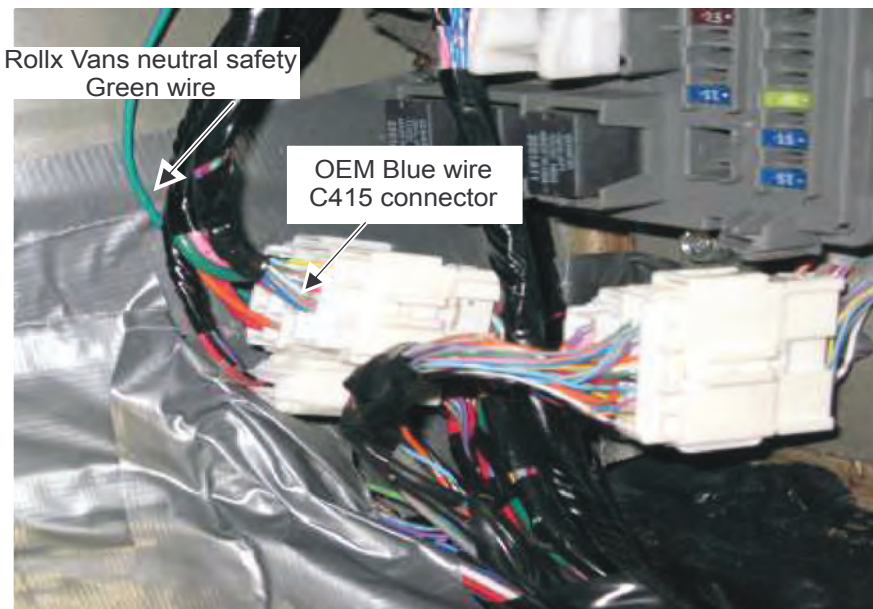

Rollx Vans neutral safety Green wire

OEM Blue wire C415 connector

OEM Neutral Safety (Near Passenger Side Kick Panel)

The neutral safety that Rollx Vans uses for its OTC system is achieved by tapping into OEM neutral safety location as shown which then goes to the fuse panel.

See OTC Wiring Diagram for more information.

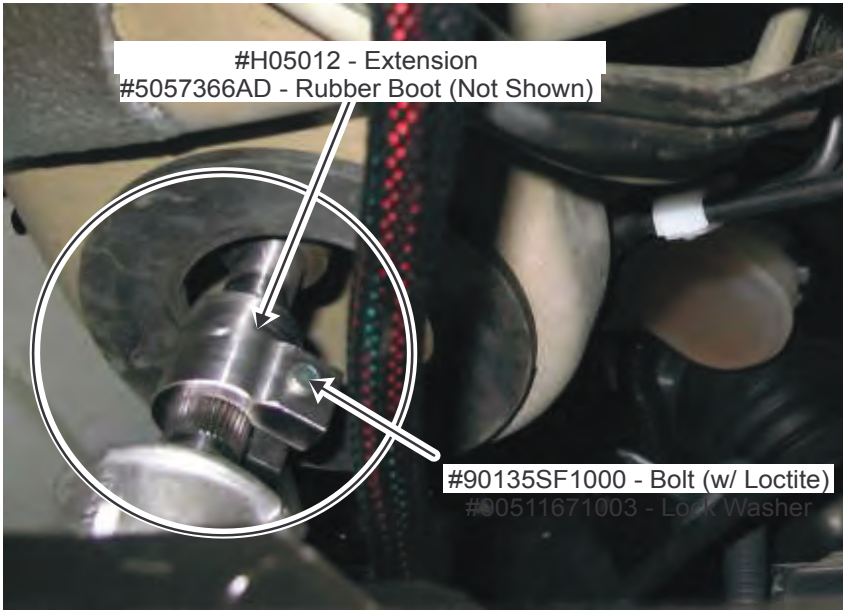

Steering Shaft Extension

Rollx Vans needs to extend the OEM Steering Shaft as shown.

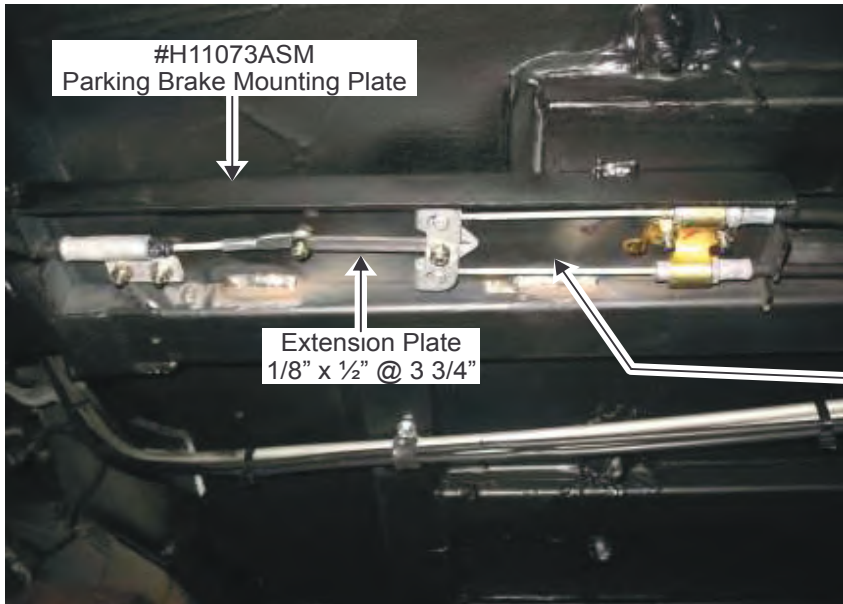

Bracket for OEM Parking-Brake (Underneath Front Left of Van)

Parking Brake Cover
#H11074

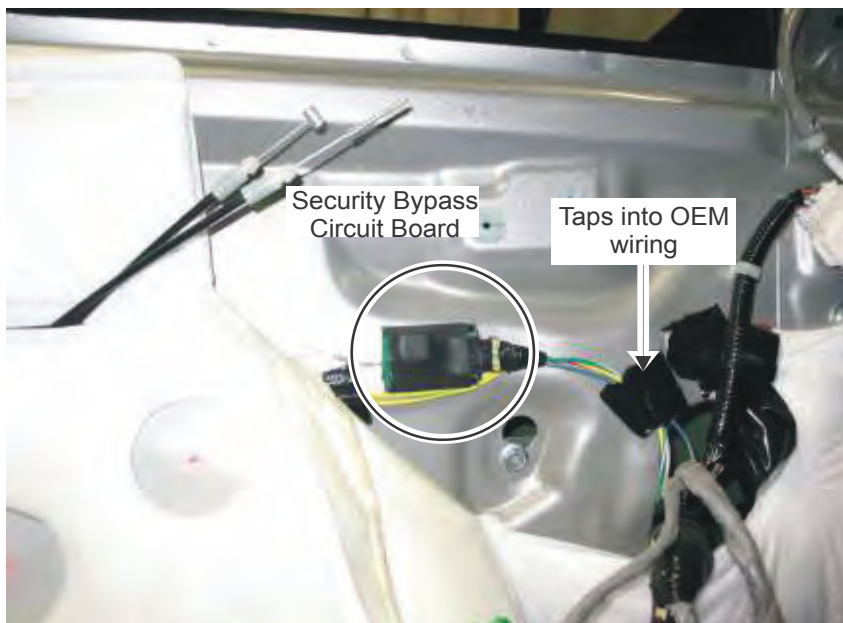

Rollx Vans Security Bypass Circuit (Driver's Door)

Part: #09006-001

This Feature allows the OTC board to unlock the OEM doors when the security system is armed.

See OTC Wiring Diagram for more information.

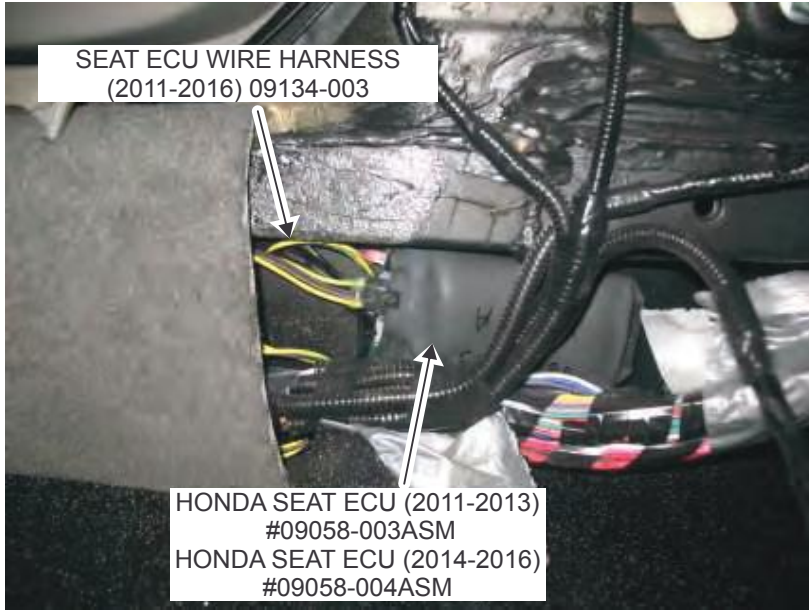

Rollx Vans ECU (Passenger Side Near Lower B-Pillar)

Rollx Vans installs a Electronic Control Unit which is called the “Seat ECU” in conjunction with a “Seat Detector” (located under the driver and passenger dash area) so that the front seats can be removed without activating a DTC Error in Honda’s computer, or turning on the airbag indicator on the front dash.

Please see Seat Power and Airbags Section for more information.



Passenger Side Slider Door Motor and Control Unit (Behind Rear Inner Trim Panel)

The slider door motor has 2 cables coming out of either side which connect to the middle roller arm on the door and pulls the door in either the open or closed direction.

Note: If either the Door Motor or the Door Control unit is replaced you must order a #11098-001ASM from Rollx Vans Service Dept.

The door control unit is inside the casing of the motor

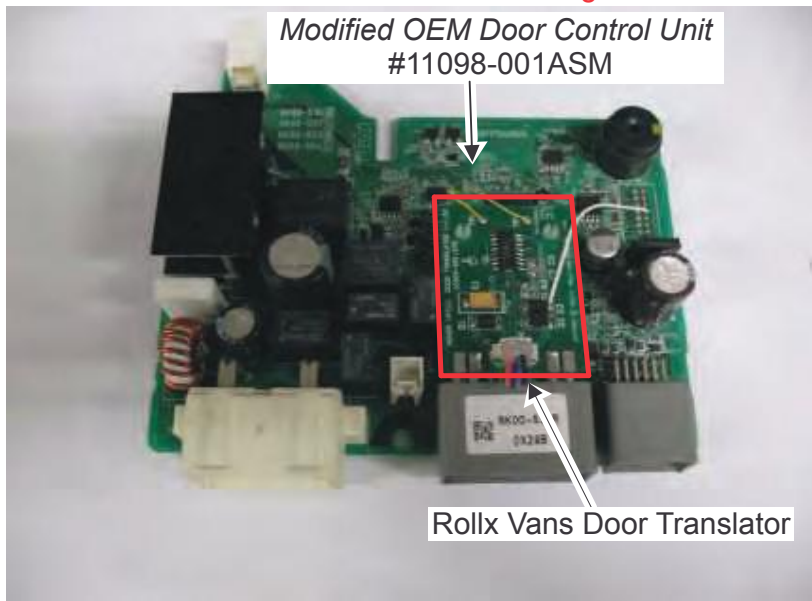

Passenger Slider Door Control Unit with the Door Translator

Rollx Vans installs a “Door Translator” which is mounted onto the door control unit.

The door translator reads the pulses off of the motor and sends the information to the door detector, the door detector then determines which state the door is in and sends that information to the OTC board. **In DEBUG mode on the OTC board You can see the door open/closed limit inputs.**

Battery Information - Draw Test Procedure



The following procedure should be used to test the current draw from any battery used in our vans.

- 1) Insure the battery is fully charged.
- 2) Remove the key from the ignition switch.
- 3) Close all the doors including the sliding doors and the rear tailgate.
- 4) Close all the windows including the rear vent windows.
- 5) Remove the negative (Black) cable from the battery and move it to a safe location away from both the positive (Red) and negative terminals of the battery.
- 6) Acquire a Digital Multimeter with a 20 Amp current range function. **NOTE: A standard van can draw between 15 and 17 amps of current when it is first powered up (When the battery is reconnected). You must use a multimeter with a 20 Amp range. Using a Multimeter with a lower current range function will damage the meter if it does not have an internal fuse. If it has an internal fuse, it will be blown.**

NOTE: DO NOT RUN THE ROLLX VANS OTC OR TRY TO START THE VAN WHEN YOU HAVE THE METER CONNECTED! YOU WILL DAMAGE THE METER!

- 7) Place the function switch of the Multimeter in the 20 Amp Current Measurement position.
- 8) Connect the negative (Black) probe (wire lead) to the black jack on the multimeter.
- 9) Most multimeters have more than one red jack for the positive (Red) probe. They usually have one jack for measuring AC & DC voltage and resistance, along with a second Jack for measuring AC & DC Current. Some multimeters have more than one red jack for measuring current (three red jacks total). As an example a meter might have two red jacks, one rated for 200 Milliamps and a second for 20 Amps. You should use the 20 Amp plug (or the one with the largest rating).
- 10) Acquire two test jumpers with alligator clips (Radio Shack # 278-002). Attach one jumper to the positive (Red) probe and the other to the negative(Black) probe.
- 11) Turn the multimeter on.
- 12) Attach the other end of the jumper clipped on the positive (Red) meter probe to the disconnected battery cable.

NOTE: Polarity does not matter much when measuring current. A positive current is the same as negative current. Disregard the polarity indicator on the multimeter during these tests.

- 13) Attach the jumper on the negative (Black) meter probe to the negative terminal of the battery.

NOTE: YOU MAY GET A SPARK WHEN YOU ATTACH THE JUMPER. THIS IS NORMAL. ALL THE CURRENT BEING USED BY THE VAN IS NOW RUNNING THROUGH THE METER. AS MUCH AS 15-17 AMPS).

- 14) The Multimeter should now show a reading. Keep you eye on the meter and watch the draw. A typical van can have from 18 to 28 computer modules in it. They are all woke up when power was applied to the van by attaching your meter probes. As you watch the current reading you will note that it will start to fall. This happens as the computers in the van decide they are not needed and put themselves to sleep. Chrysler says it can take up to thirty minutes for everything to go into sleep mode.

The current should drop in stages similar to the sequence below:

- a. The reading will start as high as 15-17 amps for a short period of time.
- b. It then fall to 6-8 amps for a short time.
- c. Then 1 to 1.5 amps for a period of time.



Battery Information - Draw Test Procedure

- d. It will then settle on around .800 amps (800 Milliamps) for a while.
 - e. Then it may drop to .100 to .200 amps (100 to 200 Milliamps) for period of time.
 - f. Finally it will drop all the way into sleep mode, .040 to .100 amps (40 to 100 Milliamps) and will stay there until the van is woke up.
 - g. **Note:** The values you will see will vary from van to van, from van type to type and by the number and type of accessories installed on the van. The important thing is that it drops to a value less the 100 Milliamps (.100 Amps) for a standard Van when it goes into sleep mode.
- 15) You can wake the van simply by opening the drivers side door for a few seconds, then closing it.
- 16) Watch the meter again to see the van go into sleep mode again. You should repeat this test until you are satisfied the van's "Sleep Mode" is functioning correctly.



This picture shows a complete setup for a Draw Test:



Note the black probe attached to the negative terminal and the red probe attached to the negative battery cable.



This picture shows a typical multimeter. Note the current range switch settings and current probe jack markings are all in yellow for μA (Microamps), mA (Milliamps) and A (Amps).

Also note that the meter has two Jacks for current measurement, “20A” and “ $\mu\text{A}/\text{mA}$ ”. On this meter, for our Draw Test, we would place the Function Switch in the “A” (for Amps) position and plug the Red Probe into the “20A” Jack. The Black Probe always goes in the Black Jack.



Door Troubleshooting

Ramp sliding door does NOT OPEN with interior Rollx Vans user button.	Van is NOT in park or neutral.	Place van into park or neutral
	Sliding Door on/off switch located on left dash is turned to the OFF position.	Turn switch to ON position.
	OTC program failure	Press OTC reset button.
	Sliding Door windows are open.	Close. See Door Operation - OEM for more information.
	OTC reads low voltage.	Start van's engine and press OTC reset button. If door still does not open review OTC board display and contact customer service.
	Bad OTC board.	Press the OTC reset button and while in Idle Mode press a user button and watch the LED. Notice if OTC appears to be working properly. Review error codes stored and call customer service.
	Main OTC fuse (40 amp) is blown.	Replace fuse under hood by battery.
Ramp sliding door does NOT OPEN with interior OEM push buttons after pressing OTC reset button.	Sliding Door on/off switch located on left dash is turned to the OFF position.	Turn switch to ON position. If the switch is OFF, the sliding doors will only operate in manual mode.
	Van battery was reconnected without both sliding doors closed all the way.	Close all doors and reconnect the battery again.
Ramp sliding door does NOT attempt to CLOSE after ramp stows.	Ramp up limit switch is not being activated properly.	Close door manually, press OTC reset button, and press Rollx Vans user button to operate system again. If door still does not attempt to close after ramp is stowed, review OTC board display and contact customer service.
Ramp sliding door kicks back when opening or closing	Obstruction. Check for door adjustment. Check for door damage. Check for damage to door track.	Check door track for any debris and remove. Adjust door. Fix door damage. Fix or replace door track
Ramp sliding door opens and van kneels, but when door is all the way open, van unkneels and cycle ends.	OEM Door Ajar Pin Switch (Rollx Vans Door Close signal) is never deactivated when door begins to open.	If the OTC thinks the door is open and closed it will end the cycle. Examine switch / wiring.
Ramp sliding door does not seal when almost closed	Defective OEM cinch motor / Slide Motor.	Operate door manually and contact customer service.
Ramp sliding door does NOT OPEN manually with Sliding Door on/off switch located on left dash is turned to the OFF position	Door is locked.	Unlock door. When pulling door handle, pull handle out and then slide door to open.
Ramp sliding door does NOT OPEN manually from interior handle, but does from exterior handle.	Child safety lock is activated.	See OEM owner manual to deactivate child safety lock.
Ramp sliding door will NOT CLOSE manually with Sliding Door on/off switch turned to the OFF position. (Located on the drivers left dash).	Door handle is not releasing.	Pull handle to disengage latch and slide to close.
	Obstruction.	Check door track for any debris and remove.



A

A = Door Latch Cable #AR-HONDA11S

B = Window Safety Cable #AR-HONDA11L

#AR-HONDA11S

#AR-HONDA11L

B

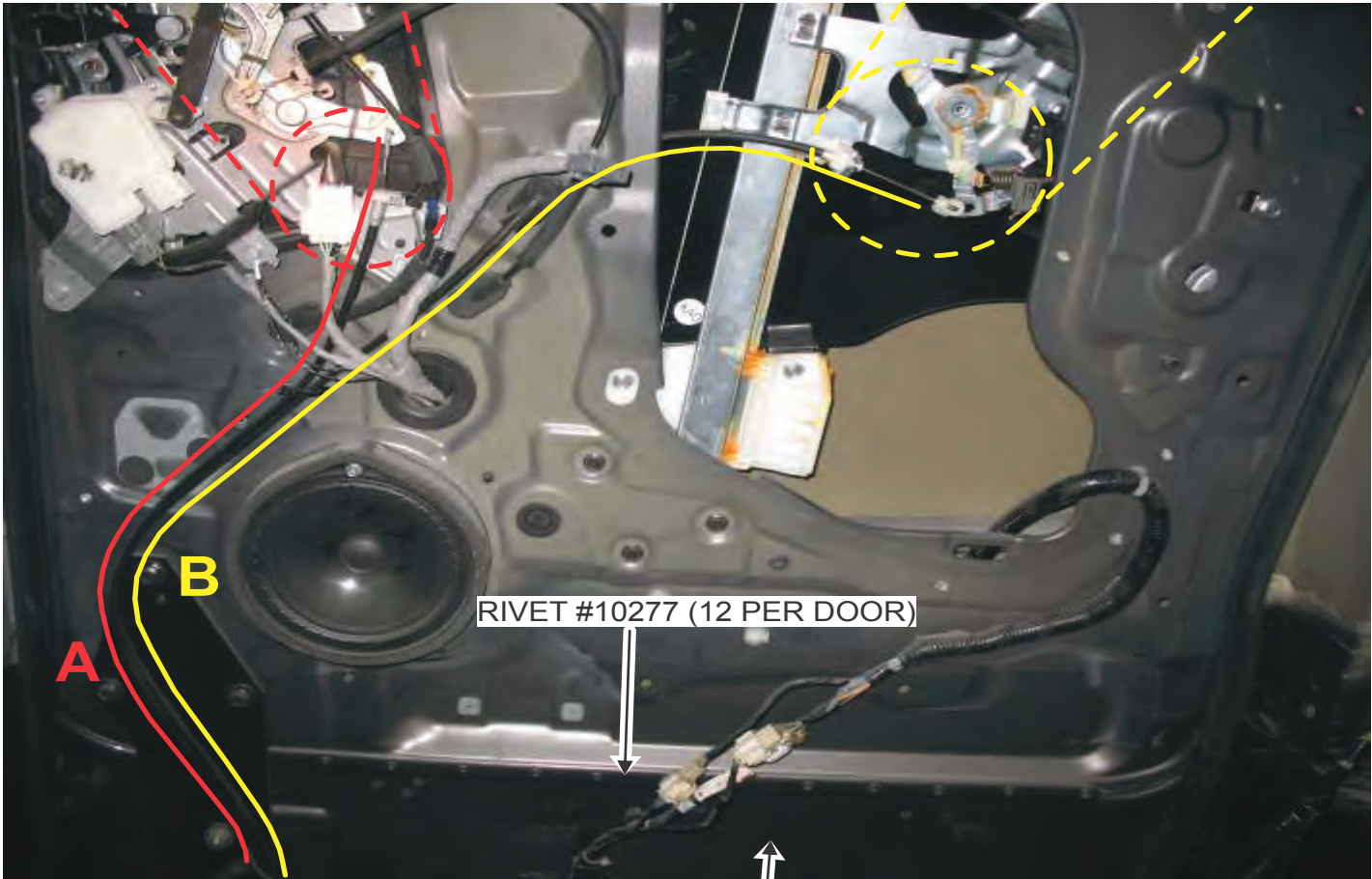
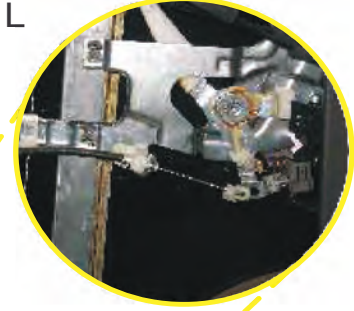

RIVET #10277 (12 PER DOOR)

*Bottom side view of lower door arm

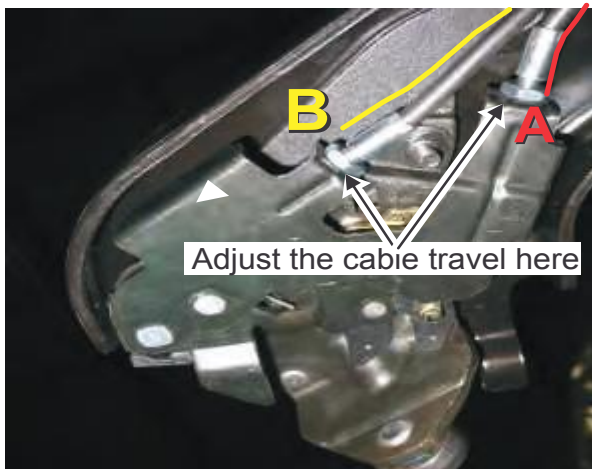

Adjust the cable travel here

-INNER DOOR SKIN PASS, HONDA #H11180-P5

-INNER DOOR SKIN DR, HONDA #H11180-D5

-L-BRACKET DOOR SKIN (NOT SHOWN) #B08180-DP6

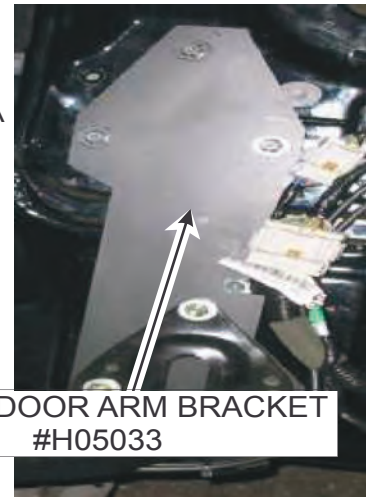

LOWER DOOR ARM BRACKET #H05033



Sliding Door Open Bracket & Harness

MODIFIED OEM SLIDING DOOR OPEN BRACKET

Passenger's Side 72543-TK8-A01

Driver's Side 72583-TK8-A01

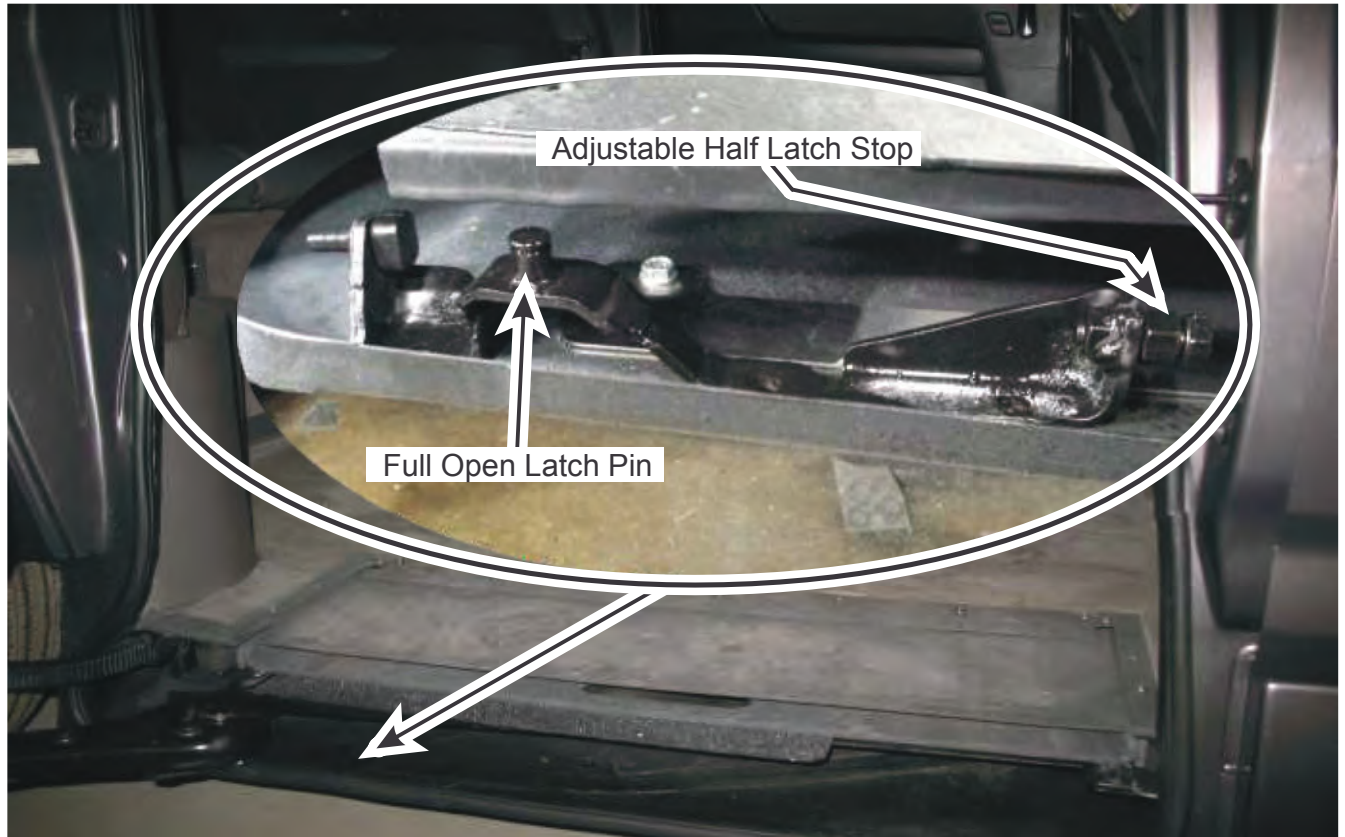

CESS HARNESS SPRING TENSIONER

#94135K4

(passenger's side shown)

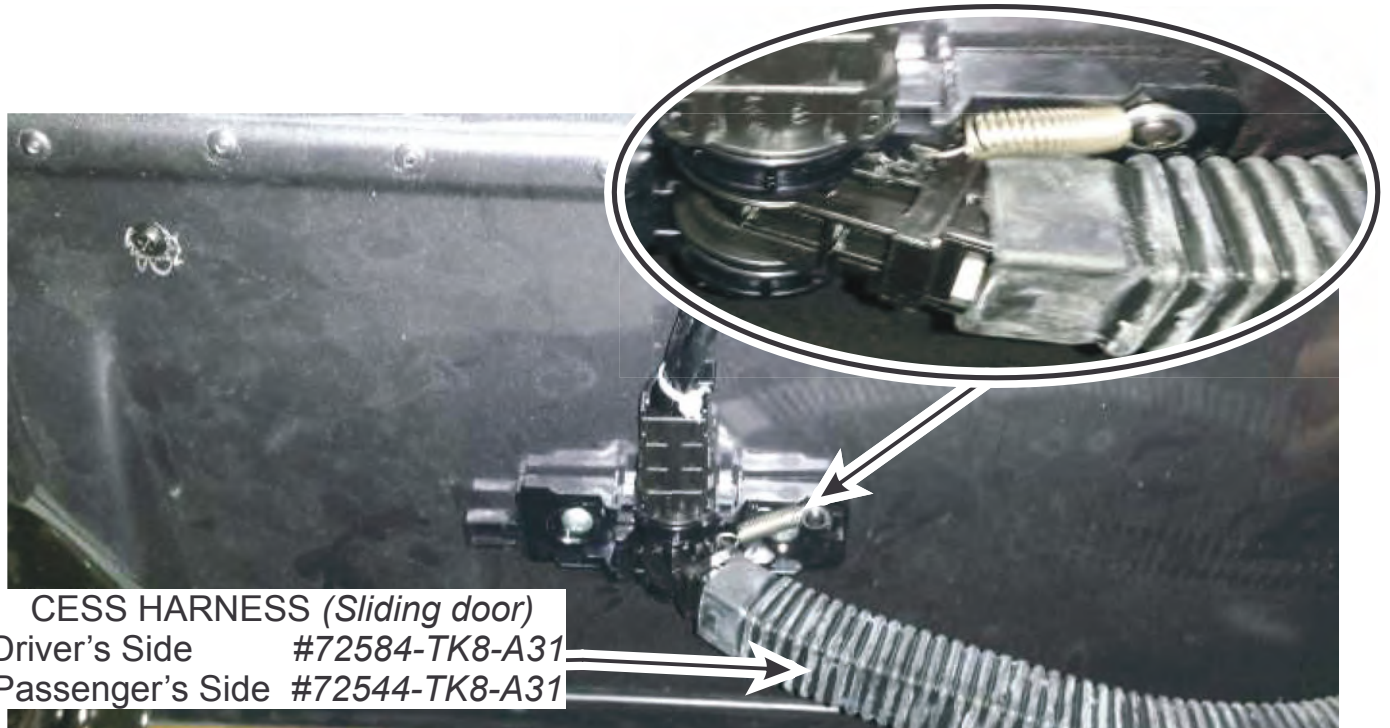

CESS HARNESS (Sliding door)

Driver's Side #72584-TK8-A31

Passenger's Side #72544-TK8-A31



Red = Rollx Vans Modifications

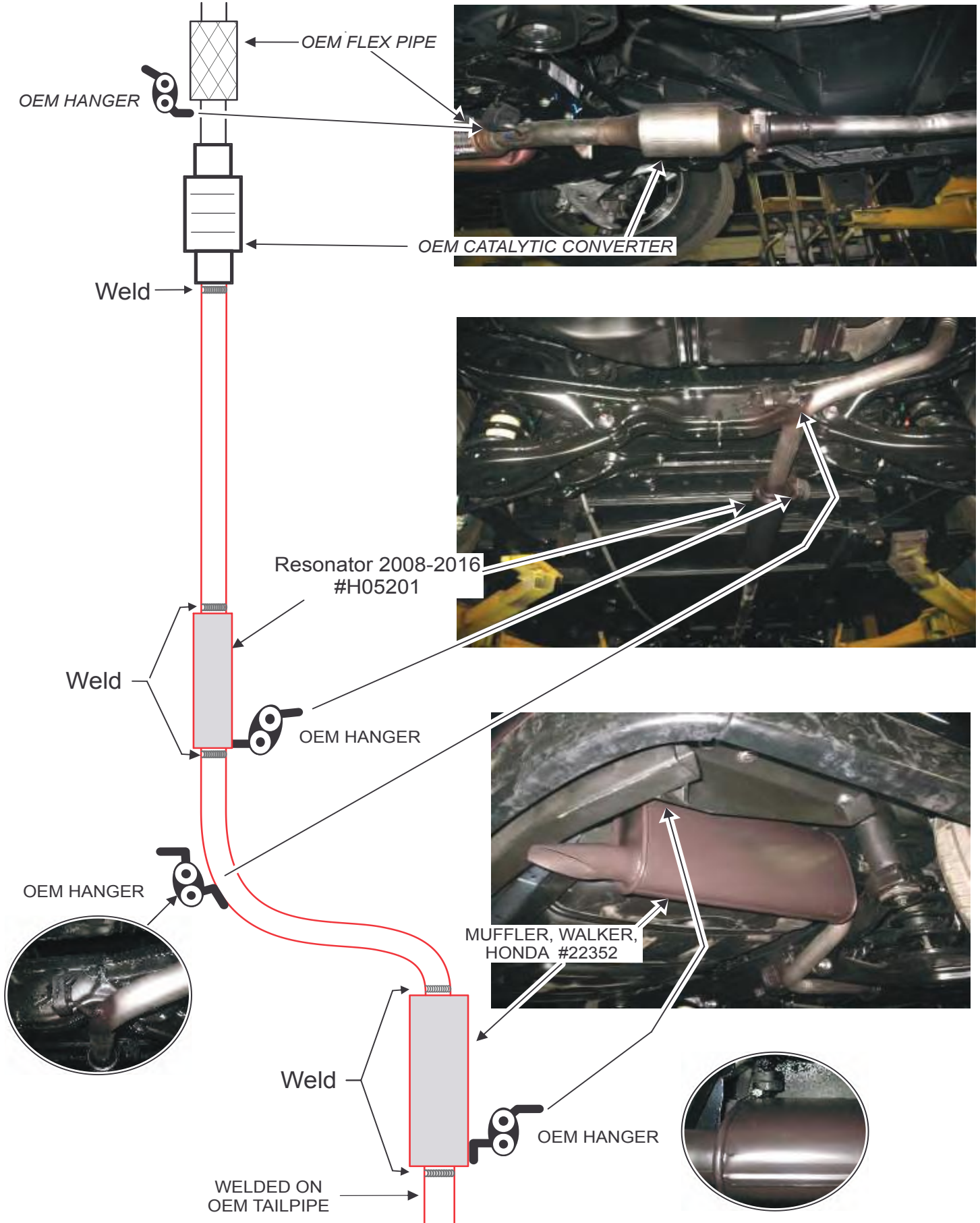



Ground Effects and Van Dimensions

-P = Passenger Side

-D = Driver Side



(Built After 9/10/2014) #H11180-P1S #H11180-D1S	Side Step Brackets (Not Shown) #H08099
---	--

(Built Before 9/10/2014) #H11180-P1 #H11180-D1	Sound Shields (Not Shown) #B12035 = Universal for Driver and Passenger Side
--	---

#H11180-P2 #H11180-D2

#H12180-P4 #H12180-D4 #H12180-C4
--

Rear Bumper Frame (Not Shown) #H11095ASM
--

For early 2011 →
without the rear
bumper ground effect

#H05180-P4 #H05180-D4

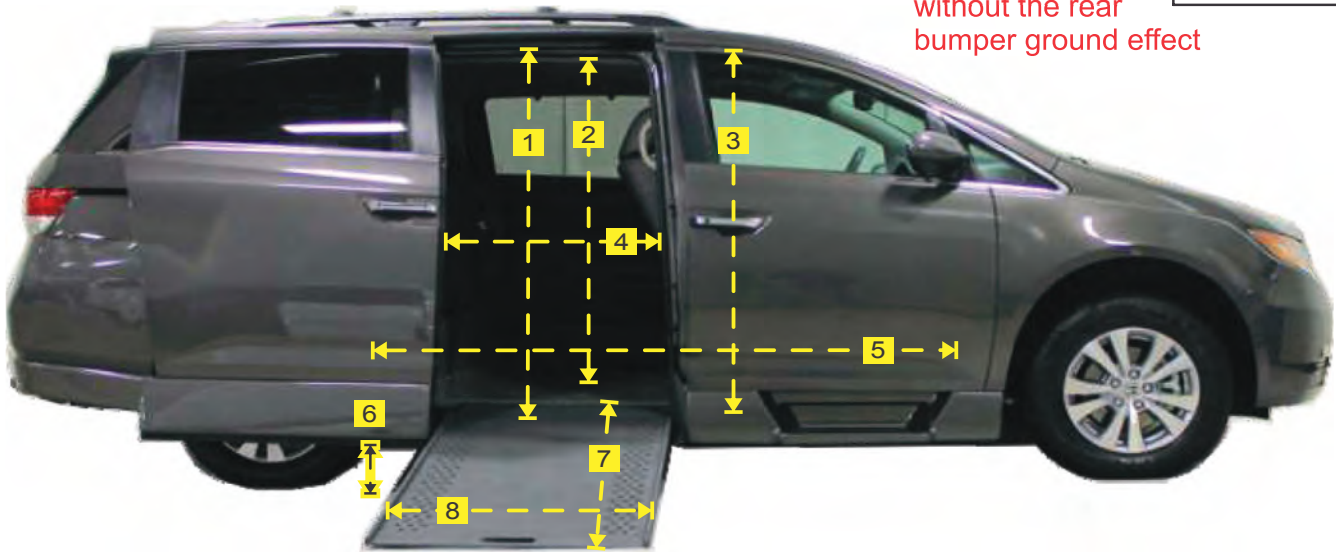

Measurement	Description	In The Floor Ramp 11 Inch Drop
1	Door Opening Height	55
2	Floor to Ceiling Height - Cargo Area	56.5 - 59
3	Floor to Ceiling Height - Front Seat Area	57 - 58
4	Door Opening Width	31
5	Floor Length (Flat Area)	85
6	Ground Clearance (Lowest Point - Exhaust)	5
7	Ramp Length	51.5
8	Usable Ramp Width	30
	Interior Cargo Area Width When Closed (Door to Door)	65
	Ground Effect Ground Clearance	6
	Cargo Area Floor Length (Rear Sofa to Clip-in Base)	54

All measurement are subject to change depending on various van configurations and should be used as approximations.



2011-2016 Honda Odyssey Rollx Fuel / Emission System Overview

*See next page for Rollx Vans part #'s

Red Text = Rollx Vans Equipment
Italic Text = OEM Parts

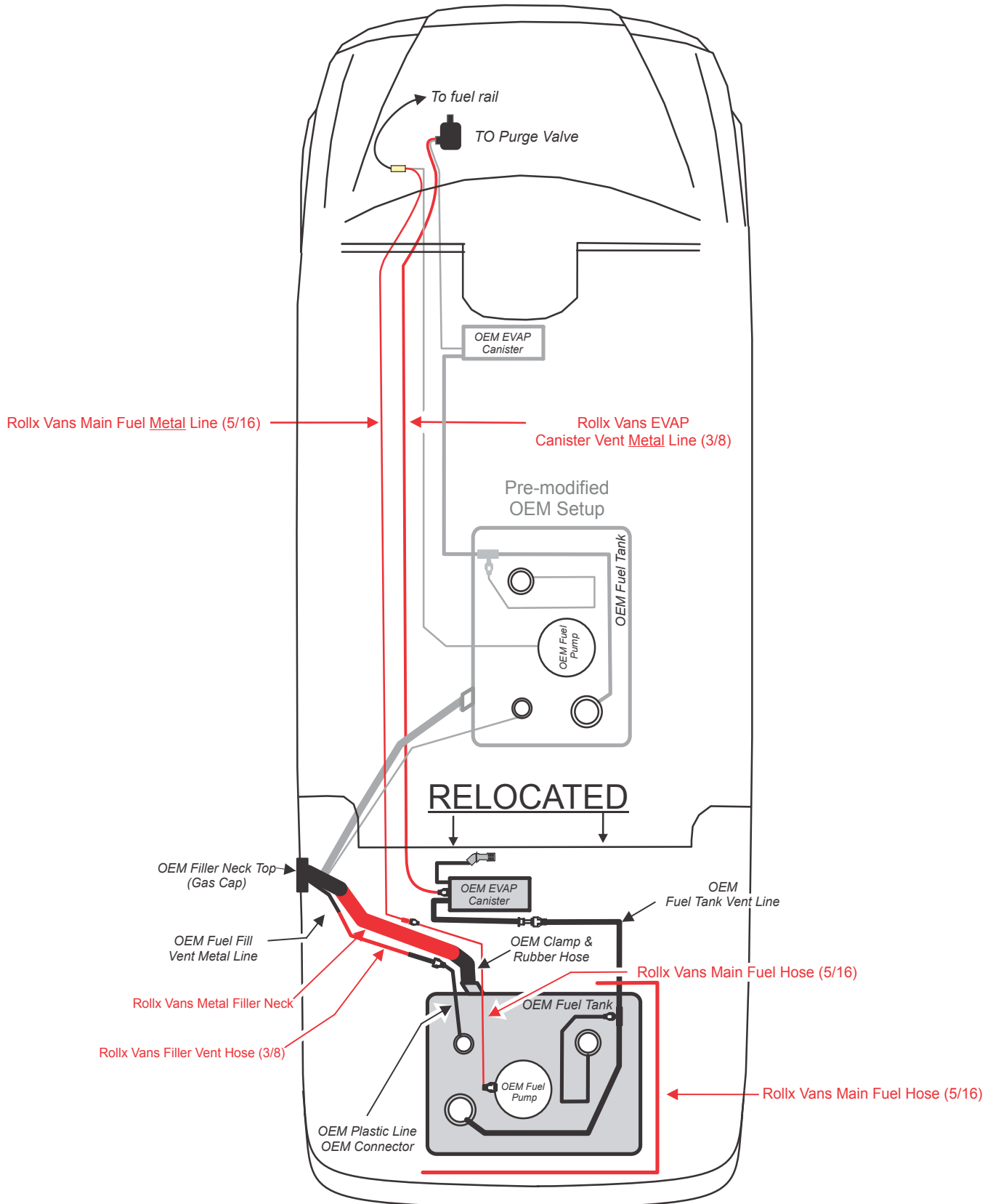

2011-2016 Honda Odyssey Rollix Fuel / Emission System Overview

Red Text = Rollix Vans Equipment
Italic Text = OEM Parts

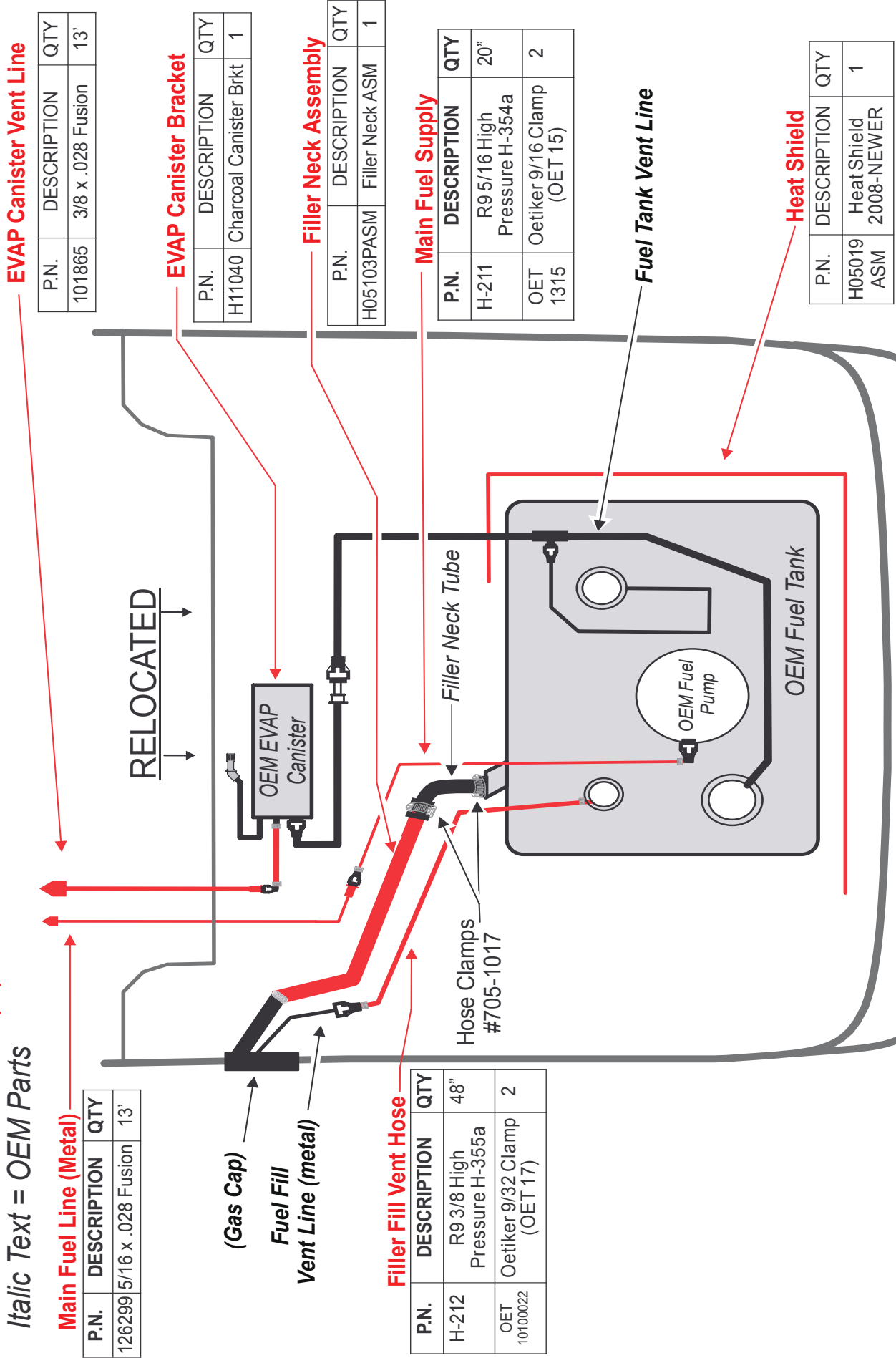

Main Fuel Line (Metal)

P.N.	DESCRIPTION	QTY
126299	5/16 x .028 Fusion	13'

EVAP Canister Vent Line

P.N.	DESCRIPTION	QTY
101865	3/8 x .028 Fusion	13'

EVAP Canister Bracket

P.N.	DESCRIPTION	QTY
H11040	Charcoal Canister Brkt	1

Filler Neck Assembly

P.N.	DESCRIPTION	QTY
H05103PASM	Filler Neck ASM	1

Filler Fill Vent Hose

P.N.	DESCRIPTION	QTY
H-212	R9 3/8 High Pressure H-355a	48"
OET 10100022	Oetiker 9/32 Clamp (OET 17)	2

Main Fuel Supply

P.N.	DESCRIPTION	QTY
H-211	R9 5/16 High Pressure H-354a	20"
OET 1315	Oetiker 9/16 Clamp (OET 15)	2

Heat Shield

P.N.	DESCRIPTION	QTY
H05019 ASM	Heat Shield 2008-NEWER	1



2011-2016 Honda Odyssey Rollx Fuel / Emission System Overview

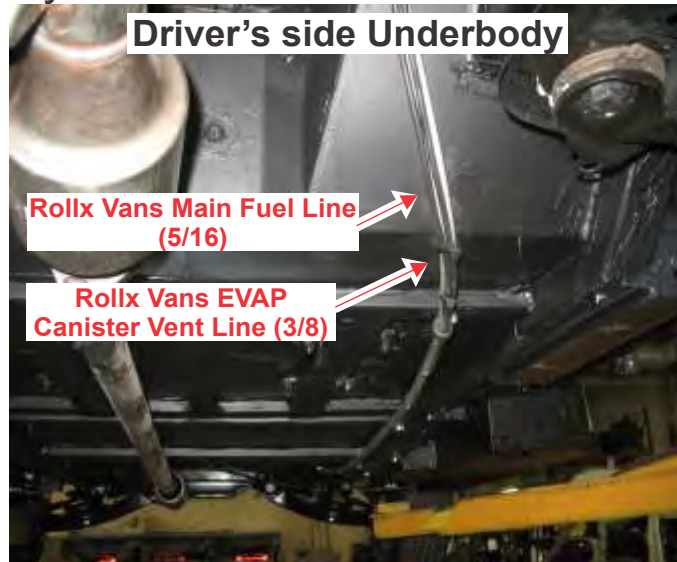
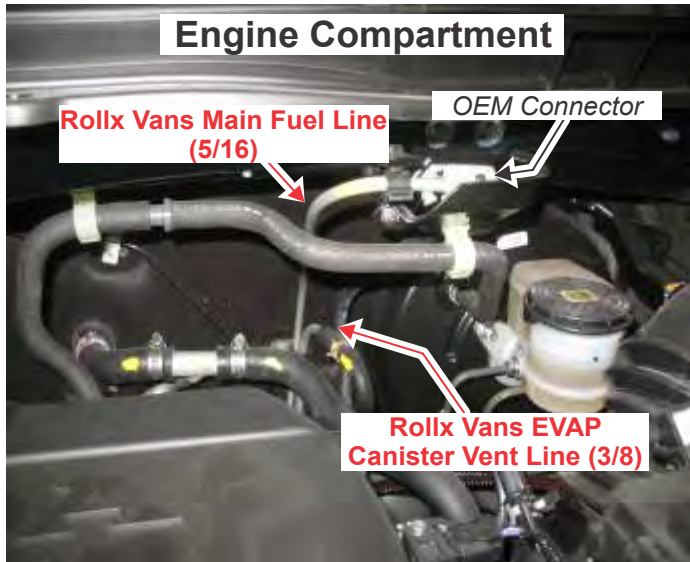

Relocated EVAP Canister and Bracket

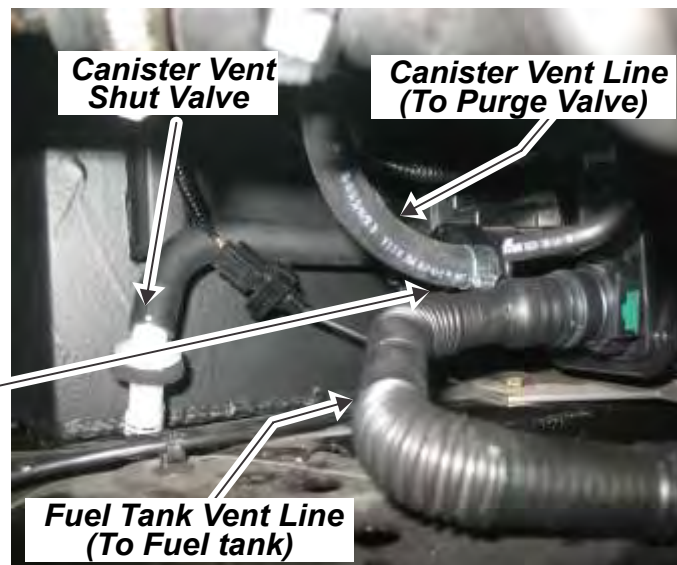
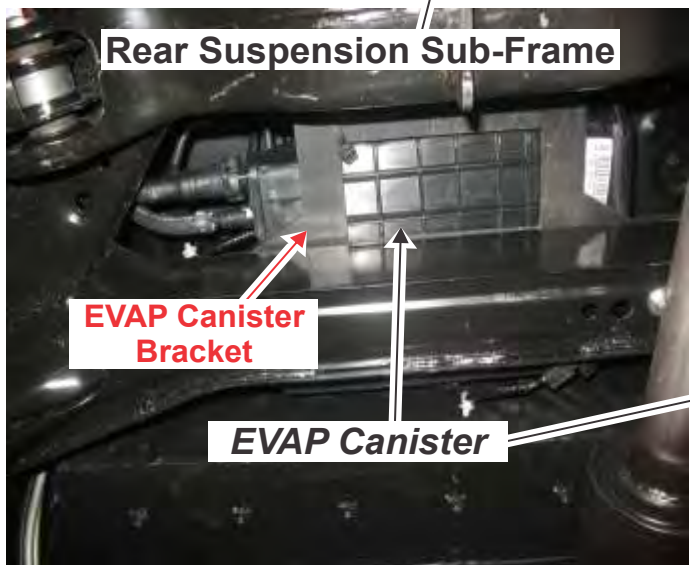
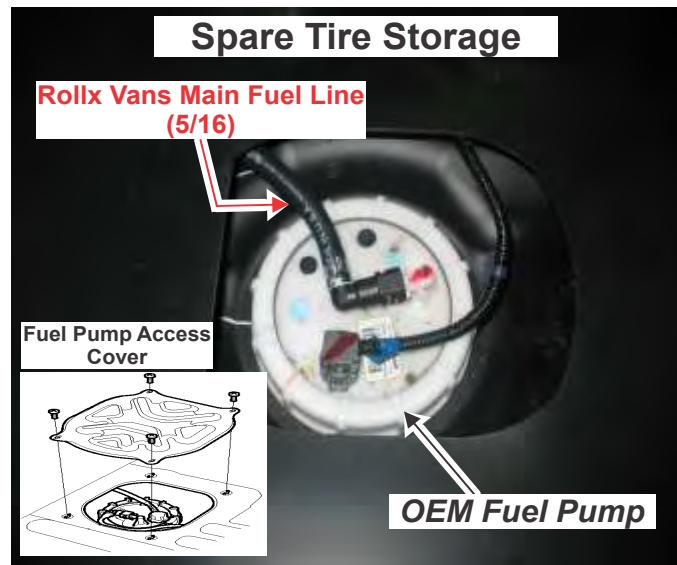
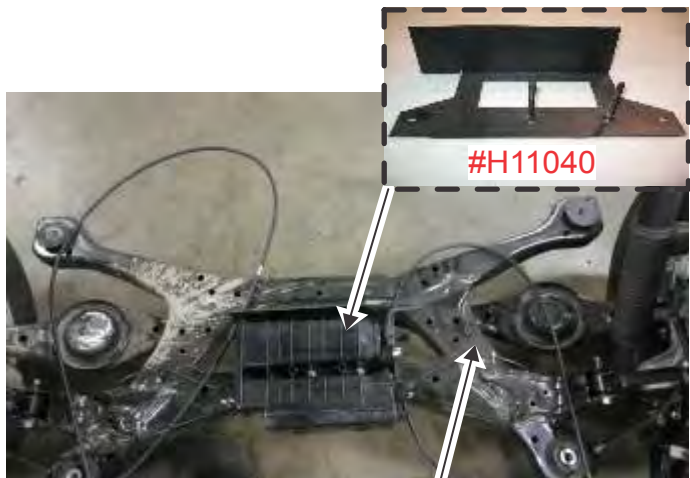



2011-2016 Honda Odyssey Rollx Fuel / Emission System Overview



Rollx Vans Weld to OEM Filler Neck

Rollx Vans Hose to OEM Clamp / Line for Fill Vent

Rollx Vans Metal Filler Neck



Rollx Vans Fill Vent Hose

Main Fuel Line
5/16" Metal Line

Main Fuel Line
5/16" High Pressure Hose

Roll Vans Metal Filler Neck
to OEM Filler Neck

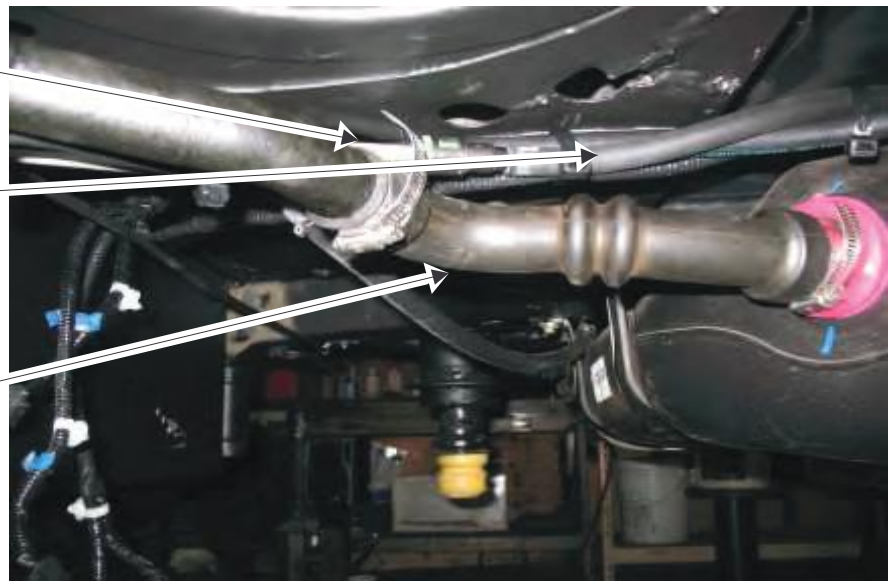

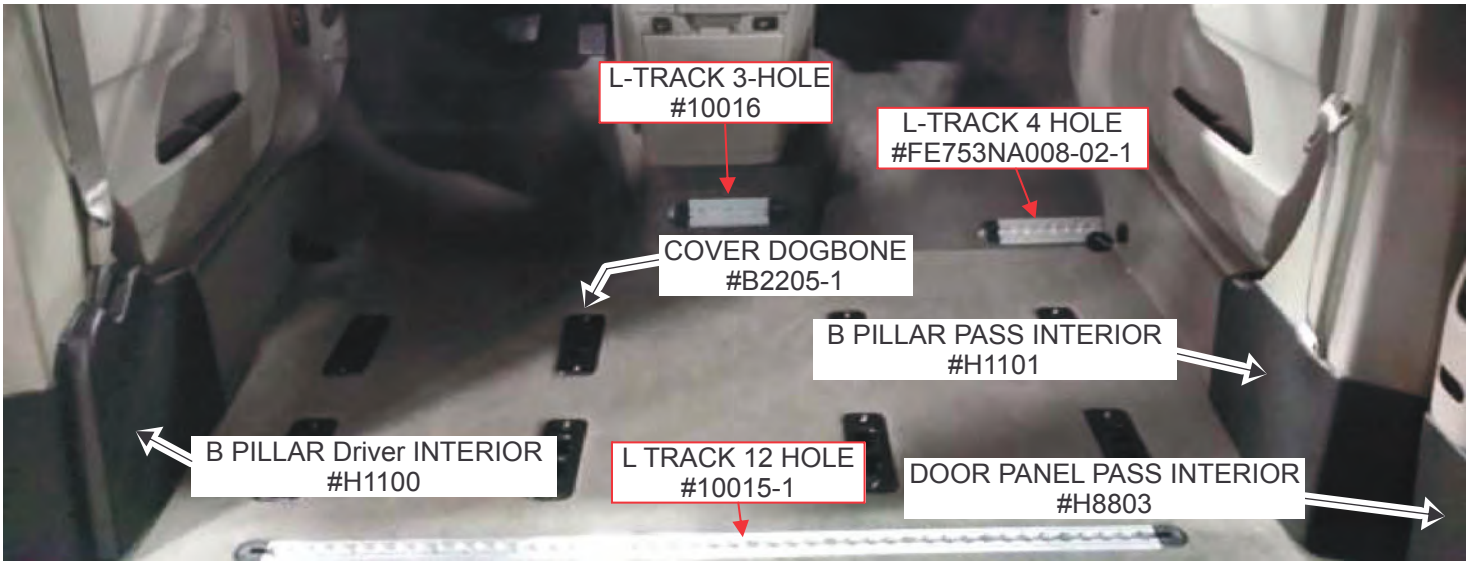

QTY	P.N.	Description
8	B2205-1	COVER DOGBONE
16	31833	8 X 1 SCREWS (for dog bone covers)
10	QC06058	END CAP FLANGE TRK OMNI
10	11263372	8x3/4 SCREWS (for end caps)
1	10016	L TRACK 3 HOLE (dog house)
1	FE753NA008-02-1	L TRACK 4 HOLE (pass front crash)
1	10006-1	L TRACK 5 HOLE (pass cargo)
1	10008-1	L TRACK 7 HOLE (rear z)
1	10015-1	L TRACK 12 HOLE (behind front seats)
24	10929-03772	5/16-18X 3/4 BOLTS (for 5/16 L-Track)
7	10929-03773	1/4-20X1 BOLTS (for 1/4" L-Track)



Spare Tire Cover



Spare Tire Cover (Open)



Fuel Pump Access Cover

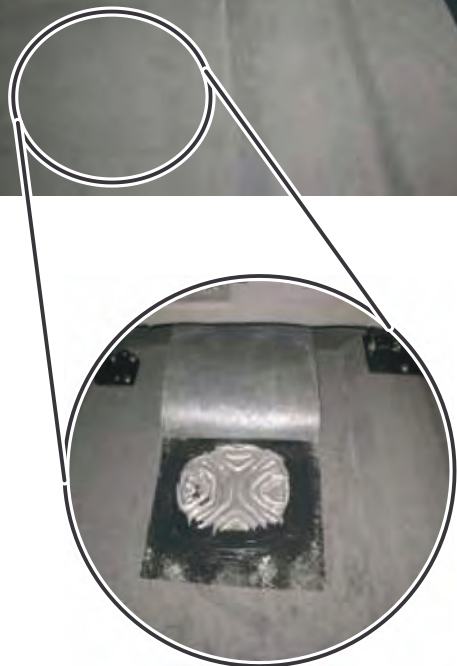
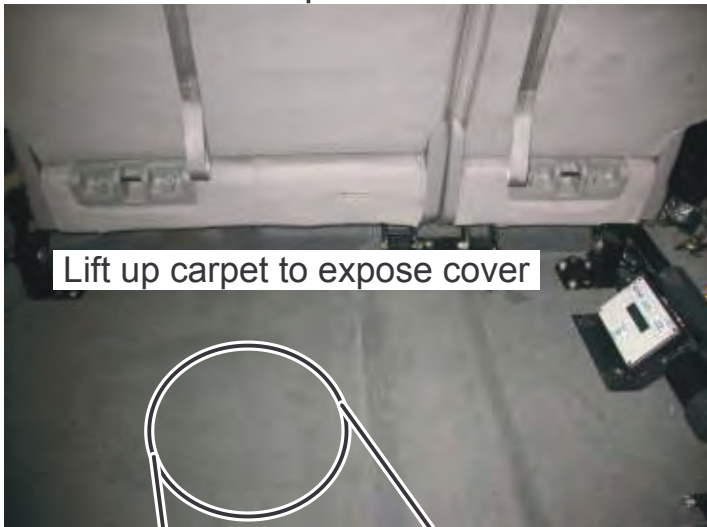

OTC Board & Kneeler

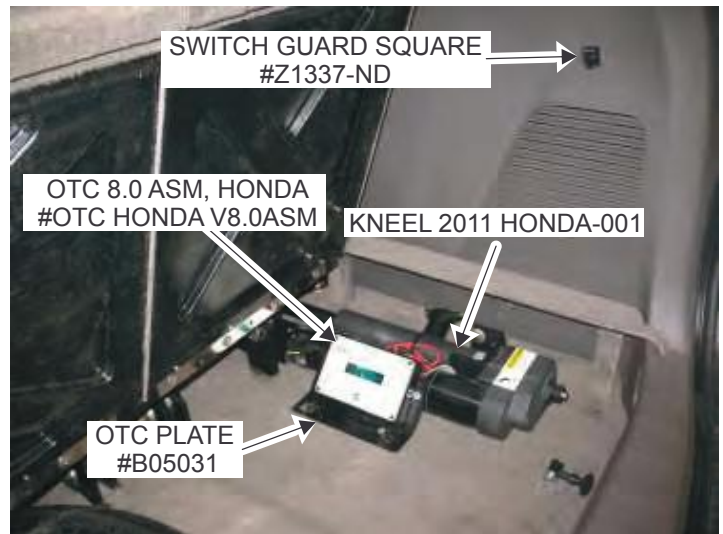

Clip In Seats

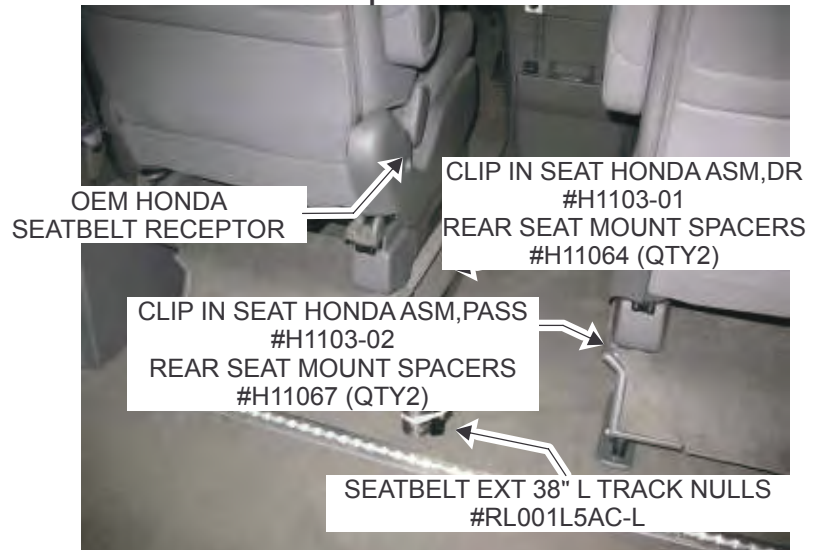



Flip Up Foot Rest

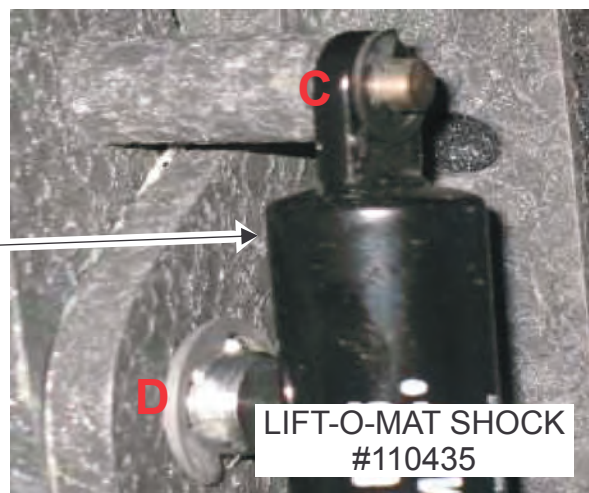
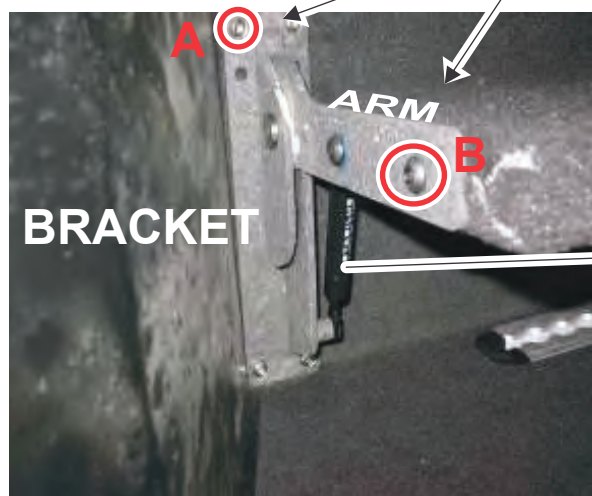
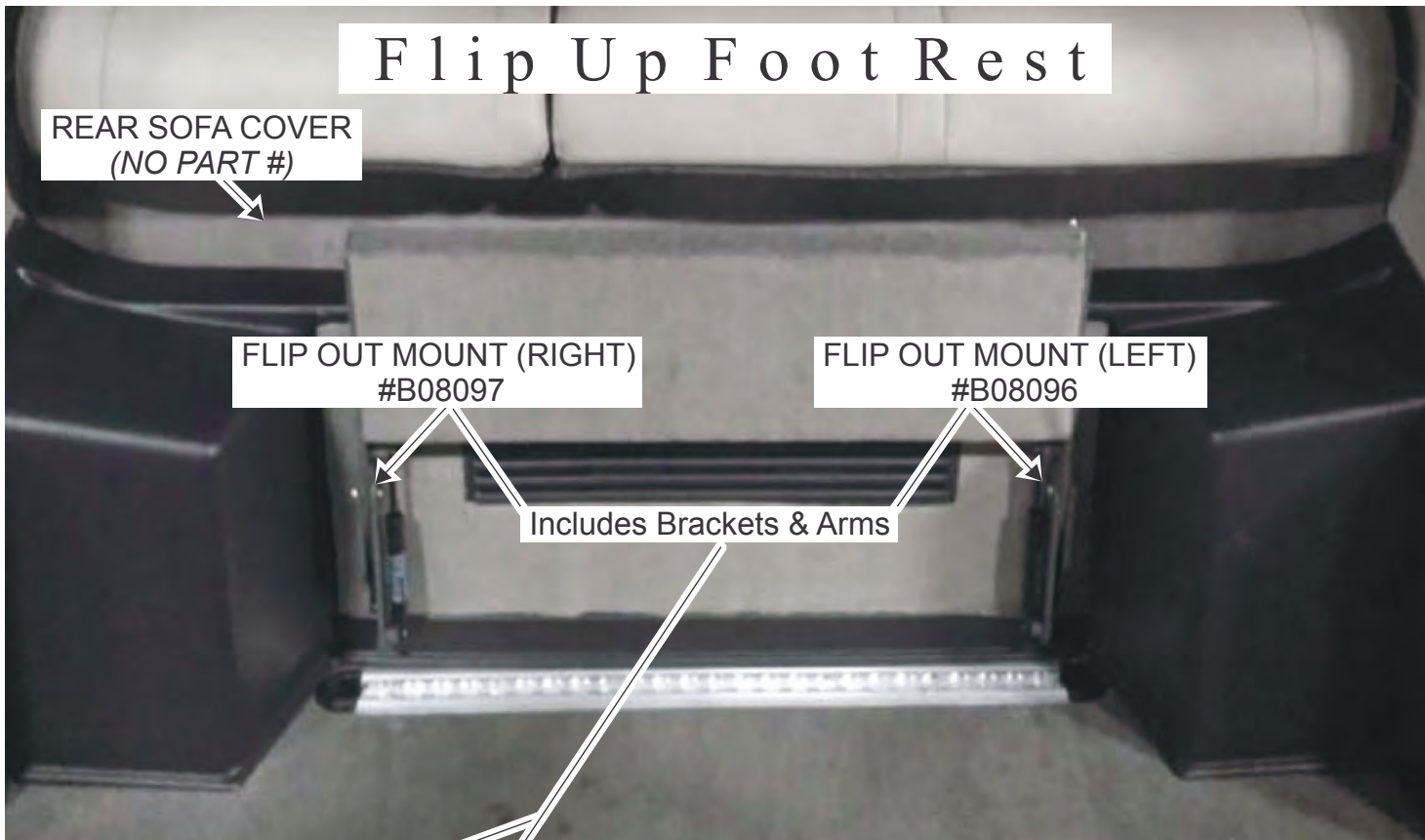

MOUNTING HARDWARE

ITEM	P.N.	DESCRIPTION	QTY
A	10929-02112	1/4 - 20 X 1/2 TORX BOLT	8
B	173780	5/16 - 18 X 1 ALLEN BOLT	4
C	1168077	1/4 E CLIP	2
D	1168081	1/2 E CLIP	2

Rear Wheel Alignment

Alignment specifications to help ensure even tire wear.

Camber Adjustment
+0.2°



Rear Toe Adjustment
+0.05° - +0.09°

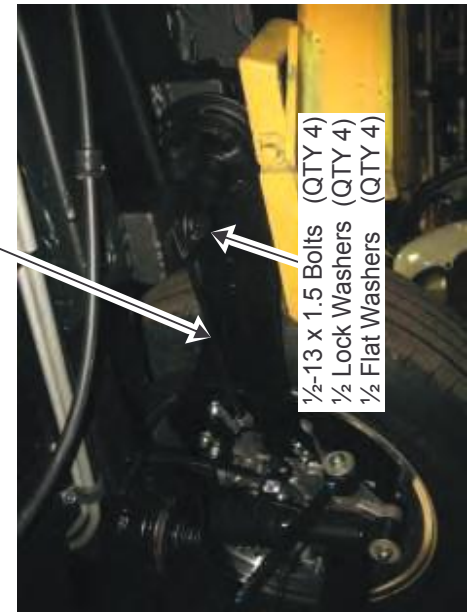
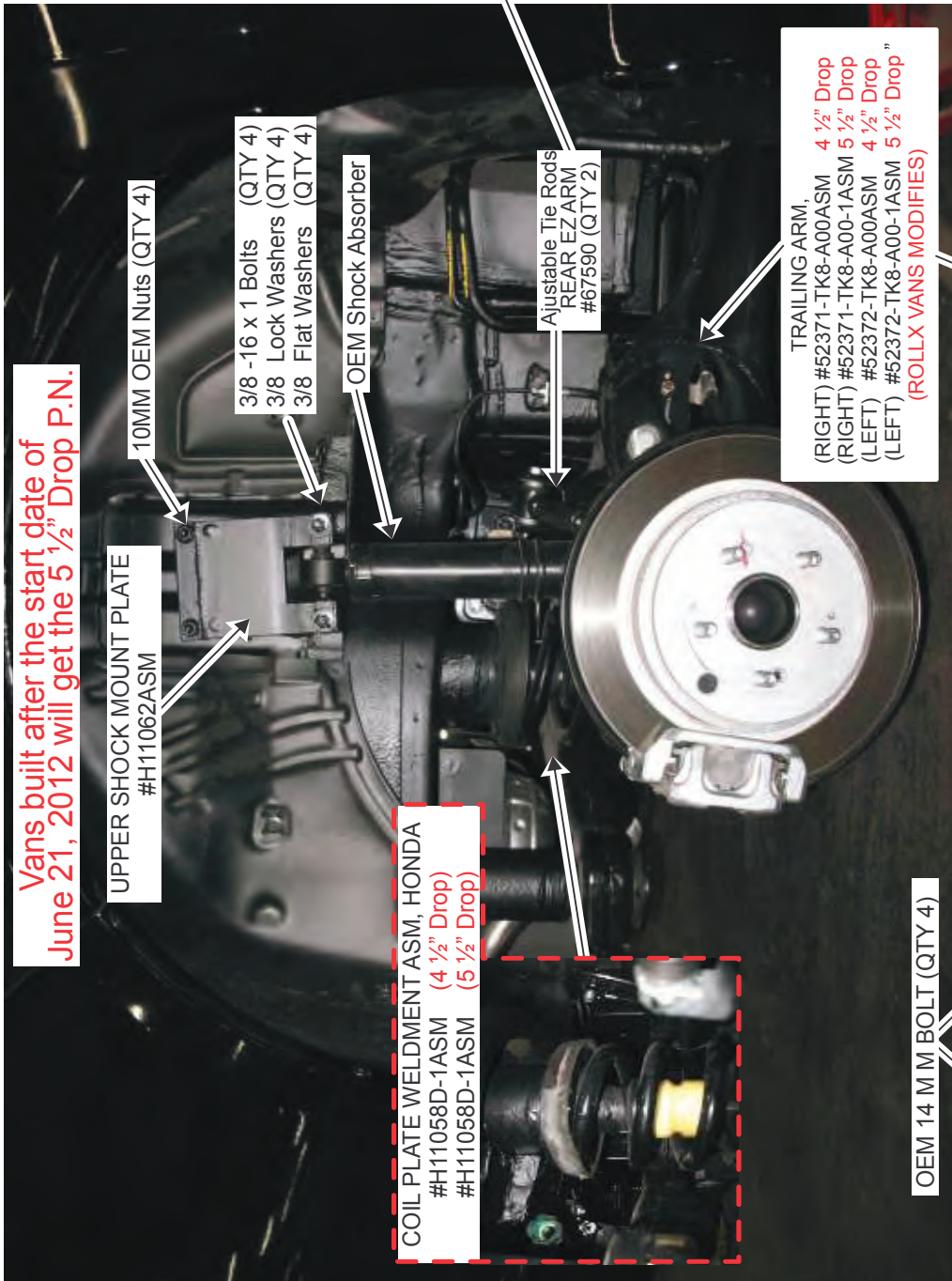
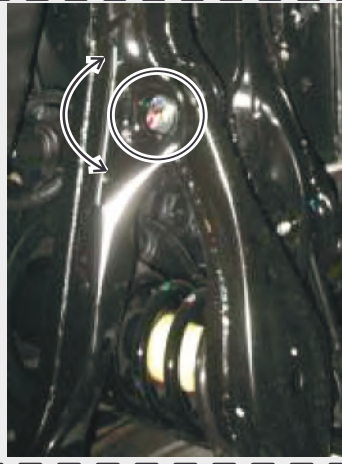



Front Strut Mounting Nuts



STRUT COLLAR ASM
#H05001ASM



OEM Mounting Nuts
Reused (QTY 6)

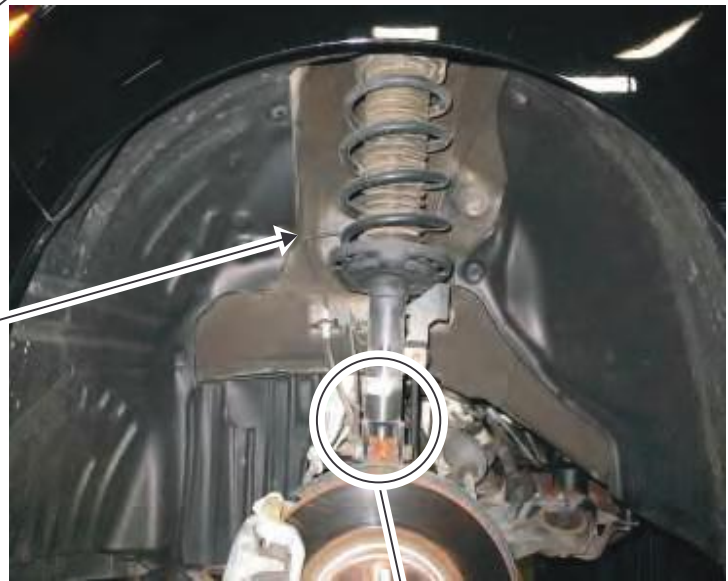

CAMBER ALIGNMENT BOLTS
#41-216 (QTY 2)



REF	DESCRIPTION	P.N.	QTY
A	2.5" MOTOR MOUNT	N05011	8
B	TRACTION BAR SPACER	B05065	8
C	M14-1.5 X 150MM BOLTS	10929-02093	4
D	M12-1.25 X 75MM	1113271	6
	(C & D) USE 1/2" FLAT WASHERS	1133012	10
E	M10 - 1.25 X 90MM	MM2610090PF0000	2
	(E) USES 3/8" FLAT WASHERS	1130088	2

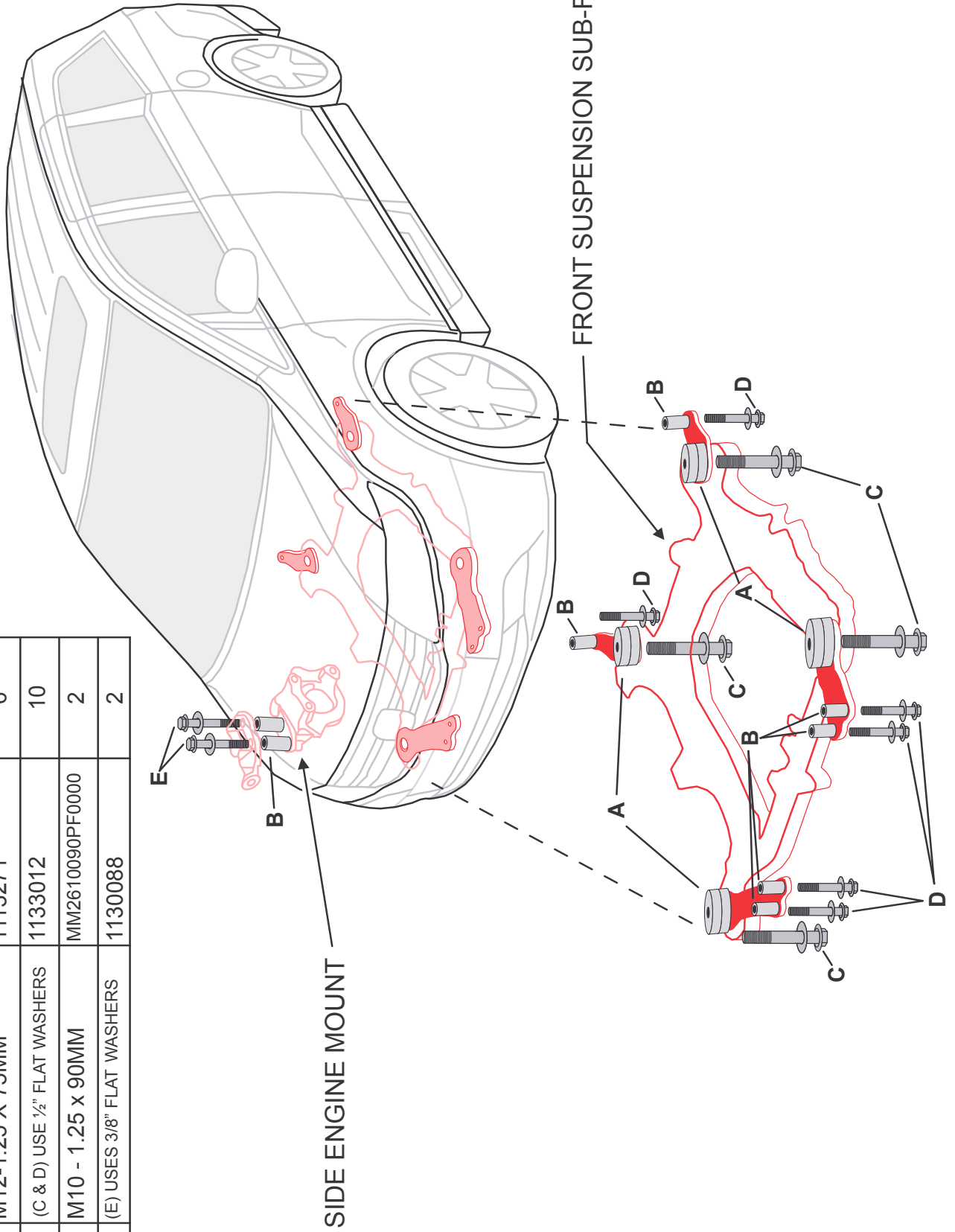



Symptom	Possible Cause	Remedy
Van does NOT LOWER to ground while door is opening after Rollx Vans user button is pressed.	Kneel on / off switch is turned OFF.	Turn kneel switch to the ON position.
	Kneel motor.	Review display board. Turn kneel switch to the OFF position and press OTC reset button. Temporarily operate sytem without kneel option enabled. Contact customer service.
After van is lowered to ground the kneeler makes a loud ratcheting sound.	Kneel down limit switch was not activated.	Adjust kneel down limit switch. Replace if broken. Contact customer service.
Van will NOT RAISE when ramp is stowed.	Kneel on / off switch is turned OFF.	Turn kneel switch to the ON position.
	Kneel motor.	Review display board. Manually un-kneel van, turn kneel switch to the OFF position and press OTC reset button. Contact customer service.
	Kneel up limit switch is activated incorrectly.	Adjust kneel up limit switch. Replace if broken. Contact customer service.
Van raises and while door closing the kneeler ratchets.	Kneel up limit switch is not activated.	Once door is closed and van is at normal height, turn kneeling switch to the OFF position and contact customer service.
Kneeler moves up and down but the van does not lower or raise	Master link is broken.	Replace master link.

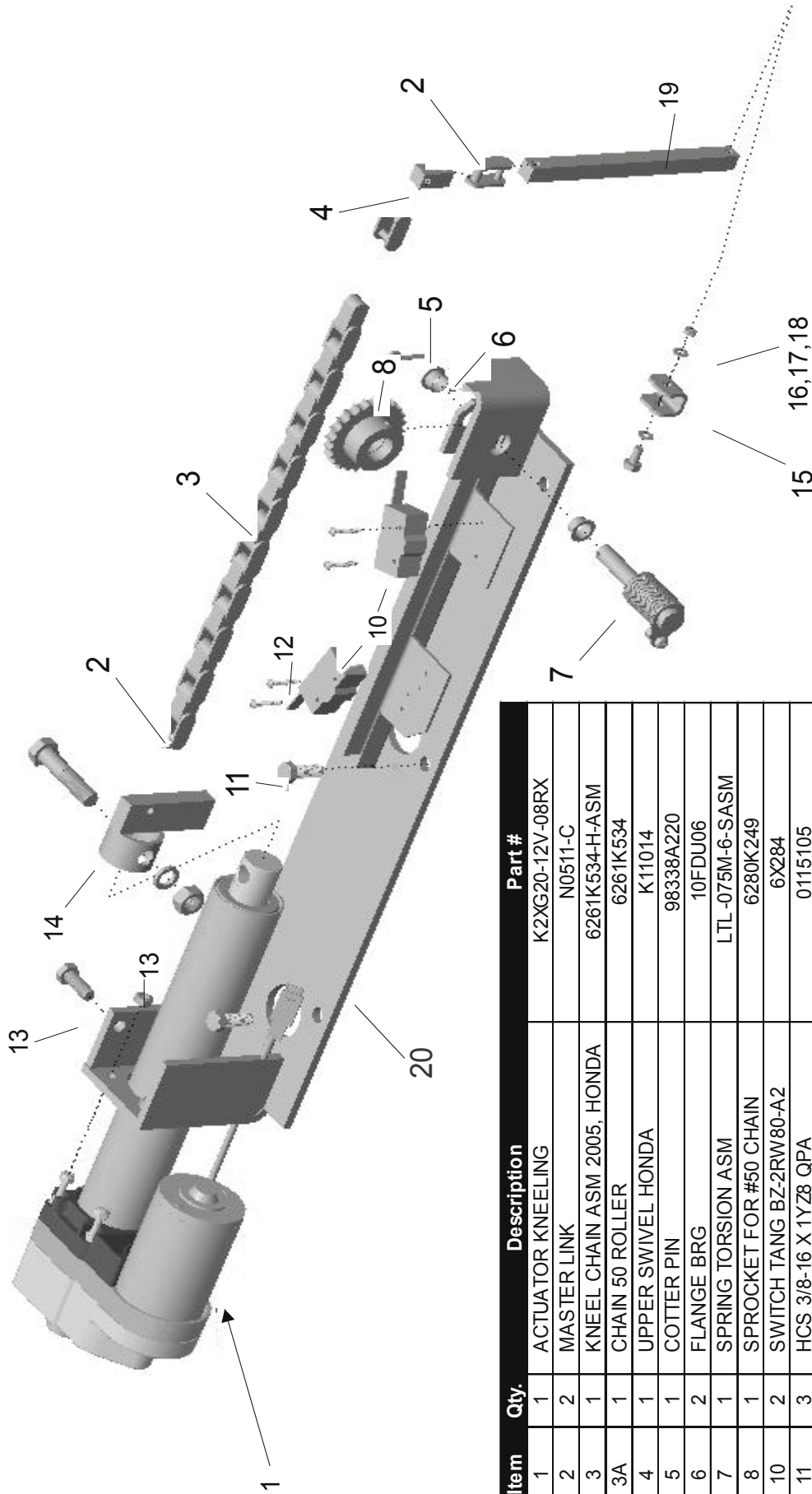

KNEEL2011 HONDA COMPLETE ASM
#KNEEL 2011 HONDA-001

(Note: Picture is for representative purpose only as some parts are in slightly different locations on a Honda kneeler)

Item	Qty.	Description	Part #
1	1	ACTUATOR KNEELING	K2XG20-12V-08RX
2	2	MASTER LINK	N0511-C
3	1	KNEEL CHAIN ASM 2005, HONDA	6261K534-H-ASM
3A	1	CHAIN 50 ROLLER	6261K534
4	1	UPPER SWIVEL HONDA	K11014
5	1	COTTER PIN	98338A220
6	2	FLANGE BRG	10FDU06
7	1	SPRING TORSION ASM	LTL-075M-6-SASM
8	1	SPROCKET FOR #50 CHAIN	6280K249
10	2	SWITCH TANG BZ-2RW80-A2	6X284
11	3	HCS 3/8-16 X 1Y28 QPA	0115105
12	4	PPH MS 6-32 X 1 1/2Z	1128838
13	4	10-32 NYLOCK NMZ	1137015
14	1	ACTUATOR GUIDE ASM	K05006ASM
Parts on Van			
15	1	KNEEL AXLE MOUNT	B05022
16	1	BLOCK TO AXLE MOUNT BOLT	115007
17	1	BLOCK TO AXLE MOUNT NUT	1137183
18	2	BLOCK TO AXLE MOUNT WASHER	1133004
19	1	HONDA KNEEL SWIVEL	K11012
	1	RATCHET AND SOCKET 3/8"	800-0072, 4PW71*
	1	BOOT BLK "2005" KNEELACT	152303*
20	1	KNEELASSEMBLY BASE PLATE	K5100BKT-H-ASM

* Not Shown

Kneeler Removal

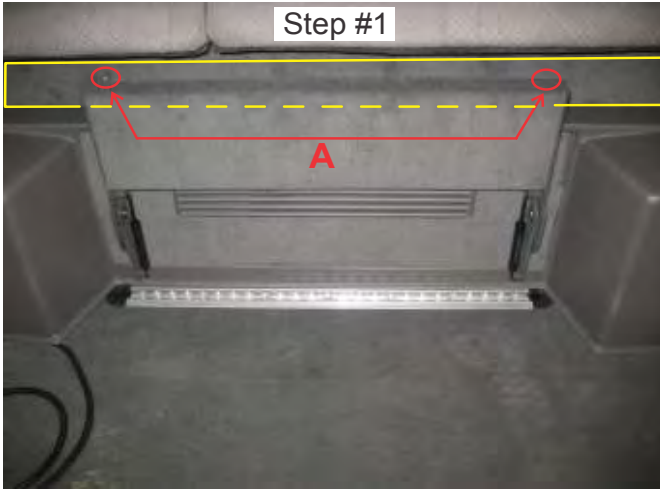

A) Remove the 2 screws for the carpeted cover then remove the cover.



A) Remove the 2 mounting brackets for the cover.

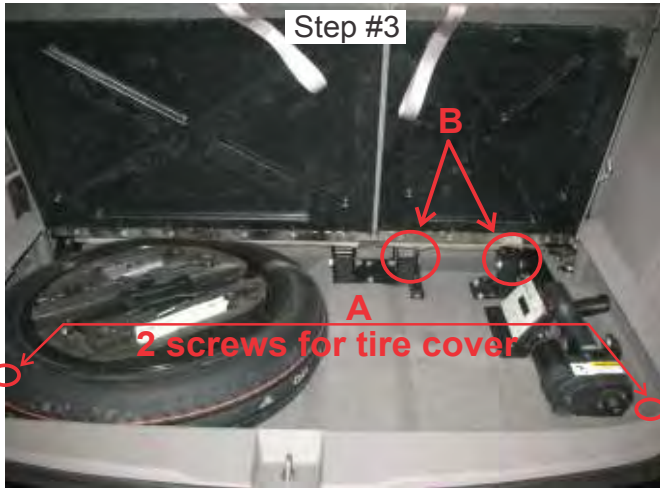

A) Remove spare tire cover.
B) Remove the 2 rear sofa mounting nuts & bolts.

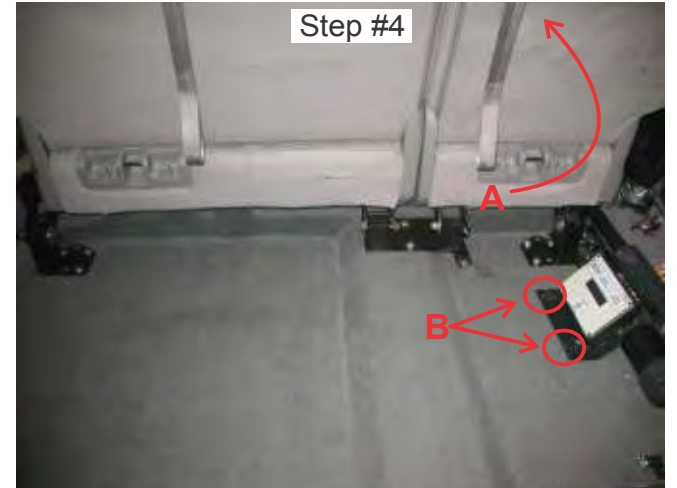

A) Flip up the right side rear sofa seat.
B) Remove the OTC mounting screws and disconnect the OTC board.



A) Remove the nut & bolt from the axle mount.

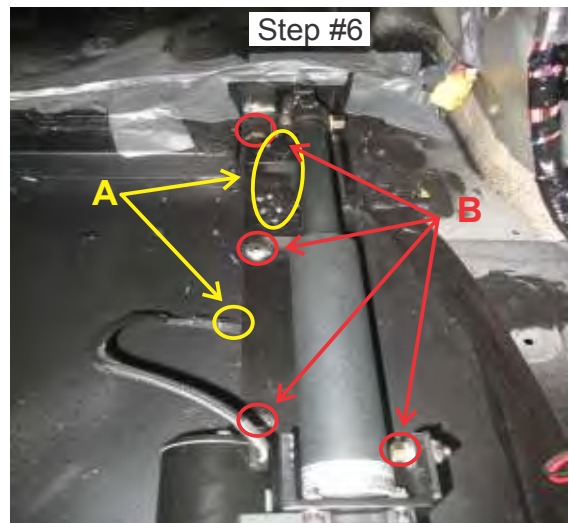

A. Disconnect the kneeler limit switch & power wires.
B. Remove the 4 mounting bolts then pull out kneeler.



This Page Is Intentionally Left Blank



Symptom	Remedy
No power to One Touch Controller (OTC).	Check that OTC ON/OFF switch is on. The power toggle switch is on the OTC board.
	Ensure the connections on the back of the OTC board are tight.
	Check the OTC main fuse (40 amp) located near the vehicles main battery.
	Check the OTC Board fuse (1 amp) located on the Rollx Vans Fuse Panel behind the glove box.
	Reset the OTC. The reset is located on the dash by the drivers left knee or on the OTC Board.
OTC beeps 4 times when the user tries to run a normal open/close cycle.	Check battery voltage.
	Battery is low. Turn off the OTC and charge battery. Note: The alarm will sound when the battery voltage is below 11.4 vdc. This is to prevent the OTC system from draining the battery far enough as to prevent the vehicle from starting. This level is adjustable in the board's Setup menu.
The van's battery is dead.	Van has been sitting for an extended period of time. Charge the battery.
	Check the current draw by placing an ampmeter in series with the negative terminal on the battery with all doors closed and engine off. The draw varies, but awake, the system should be less than .850 amps and when sleeping, less than .050 amps. Additional equipment installed will also vary these numbers. See Battery section for more information.
The OTC display is garbled.	Reset the OTC. The reset is located on the dash by the drivers left knee or on the OTC Board.



The Rollx Vans One Touch Controller, known as the OTC, is a Single Board Computer specifically designed for the Rollx Vans system.

The OTC system was designed to be independent to the operation of the Honda's computer system. When power is removed from the OTC, it has no effect on the operation of the Honda system.

The OTC is a low power system. When the OTC is in Sleep Mode with the Display disabled, it typically draws less than 10ma of current from the battery. When awake in Idle Mode (not running a cycle) with the Display enabled, it typically draws less than 200ma of current from the battery.

The current state of the OTC can be determined by viewing the Display. During and open or close operation the progress of the system can be tracked by watching the Display.



OTC HONDA V8.0

Sequence of Operation Open Cycle

- 1) The OTC is activated by any Rollx Vans User Switch or Remote being pressed.
- 2) Door unlock command sent (on 1 sec.) To Front Passenger Door Control Module to unlock all doors.
- 3) Door open command sent to OEM Door Open/Close switch circuit on the slider door control unit to open the passenger sliding door.
- 4) Door starts to open.
- 5) Kneeler motor is turned on and starts to lower van.
*If door fails to open within 2 seconds of User Switch being pressed, cycle stops (van unknuckles and cycle is ended)
- 6) Door reaches open position and activates Rollx Vans Door Detector.
- 7) Passenger sliding door is disabled by Rollx Vans OTC controller.
- 8) Ramp motor is turned on and starts to deploy.
- 9) Kneeler stops lowering when Kneel Down Limit Switch is activated.
- 10) Ramp stops deploying when Ramp Down Limit Switch is activated.
- 11) OTC enters Idle Mode.
- 12) OTC enters Sleep Mode.

Close Cycle

- 1) The OTC is activated by any Rollx Vans User Switch or Remote being pressed.
- 2) Ramp motor is turned on and starts to stow.
- 3) After a few seconds (ramp is off the ground and begins to slide into van) kneeler motor is turned on and starts to raise the van.
- 4) Kneeler stops raising when Kneel Up Limit Switch is activated.
- 5) Ramp stops stowing when Ramp Up Limit Switch is activated.
- 6) Passenger sliding door is enabled via the Rollx Vans OTC controller
- 7) Door close command sent to OEM Door Open/Close switch circuit on the slider door control unit to close the passenger sliding door.
- 8) OTC receives signal from the Rollx Vans door translator which is mounted on the passenger sliding door control unit.
- 9) OTC enters Idle Mode.
- 10) OTC enters Sleep Mode.

Note: There are "Watch Dogs" programmed in the OTC software that act as timers to end a function if the function does not complete within a certain amount of expected and very reasonable time.



INPUTS

KNEEL DISABLE SWITCH (Violet wire) Allows the user to enable (the “I” position) or disable (the “O” position) the kneeling system. There is no display for this input.

OTC CONTROLLER POWER (3 White/Red wires) Supplies power to the OTC Board

USER SWITCH INPUT (Blue wire) Active while any Rollx Vans user button or Rollx Vans remote is pressed.

NEUTRAL INPUT (Green wire) Indicates the status of the gear shifter. When active, the van is either in neutral or park. The OTC system will not run a operational cycle unless the van is in neutral or park.

DOOR CLOSE LIMIT INPUT (Violet/Yellow wire) Active when the right side sliding door is fully shut.

DOOR OPEN LIMIT INPUT (Orange/Red wire) Active when the right side sliding door is fully open.

RAMP DOWN LIMIT INPUT (Red/White wire) Active when the ramp is in the down position.

RAMP UP LIMIT INPUT (Red/Green wire) Active when the ramp in the up position.

KNEEL DOWN LIMIT INPUT (Yellow/Green wire) Active when the kneeler is in the down position.

KNEEL UP LIMIT INPUT (Yellow/White wire) Active when the kneeler is in the up position.

OUTPUTS

System Status: Indicates if the system is ready to except a command. It is off when the OTC is in sleep mode. Display will show Rollx Vans: Idle.

RAMP DOWN MOTOR OUTPUT (Red wire) Active when the OTC is driving the ramp down.

RAMP UP MOTOR OUTPUT (Red/Black wire) Active when the OTC is driving the ramp up.

RAMP ENABLE OUTPUT (Red/Blue wire) Active anytime when the OTC is driving the ramp up or down. It indicates the ramp manual mode is disabled.

KNEEL UP MOTOR OUTPUT (Yellow/Red wire) Active when the OTC is driving the kneeler up.

KNEEL DOWN MOTOR OUTPUT (Yellow/Black wire) Active when the OTC is driving the kneeler up.

DOOR DISABLE OUTPUT (Orange/Blue) Used by the OTC to disable the Honda right side door controller anytime it wants to open the ramp. This is done by interrupting the signal from the Honda Dash Door On/Off Switch so that Honda thinks that this switch is Off when the Door Disable Output is active. This prevents the right side door controller from banging the right side sliding door against the ramp.

DOOR CONTROL OUTPUT (Orange) OTC sends a command to the Honda system to open or close the right side sliding door by simulating that the Honda Dash Door Open/Close Button is being pressed.

DOOR UNLOCK OUTPUT (Yellow/Brown) OTC sends a command to the Honda system to unlock the doors at the beginning of an open cycle.

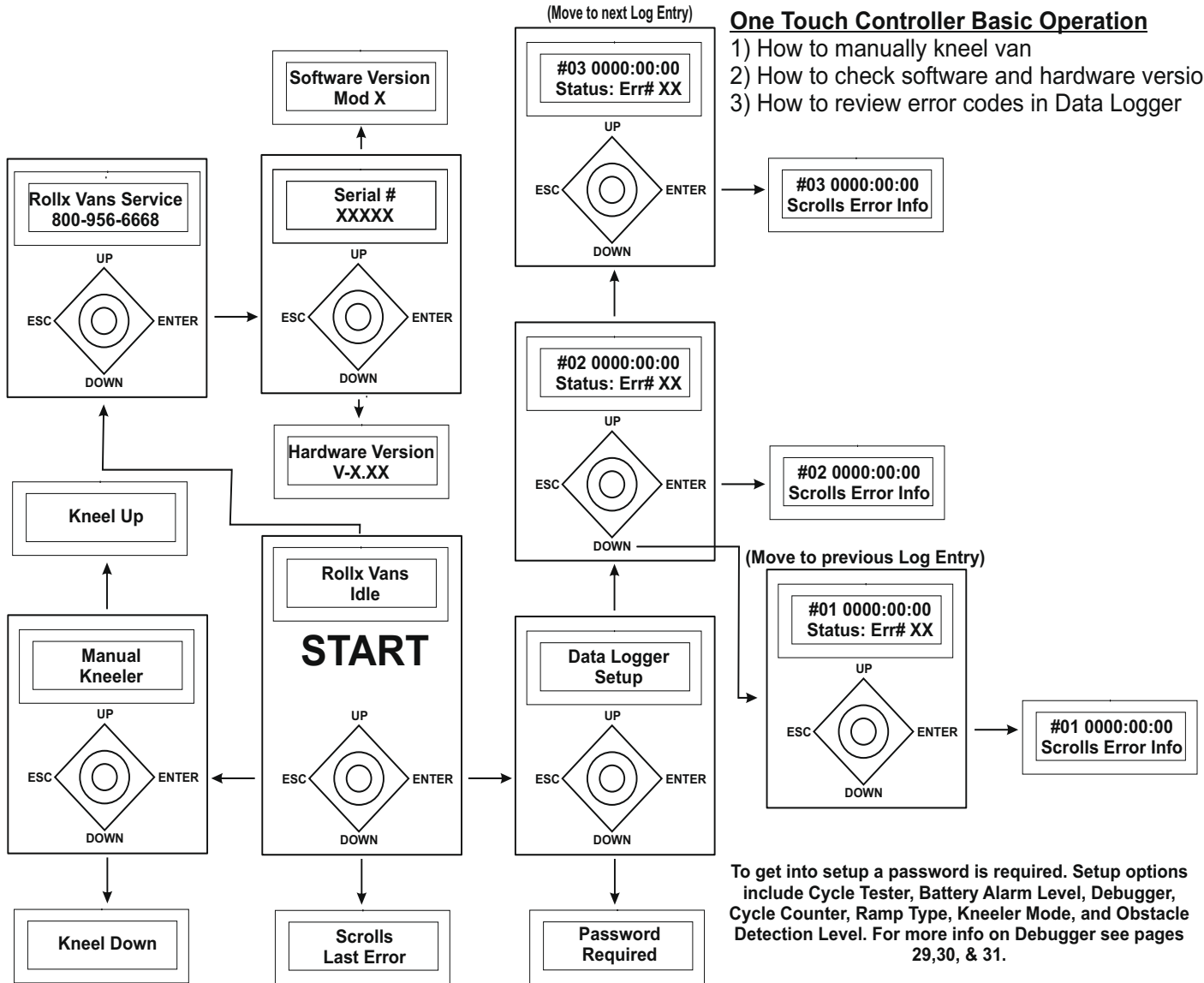



Options within Setup

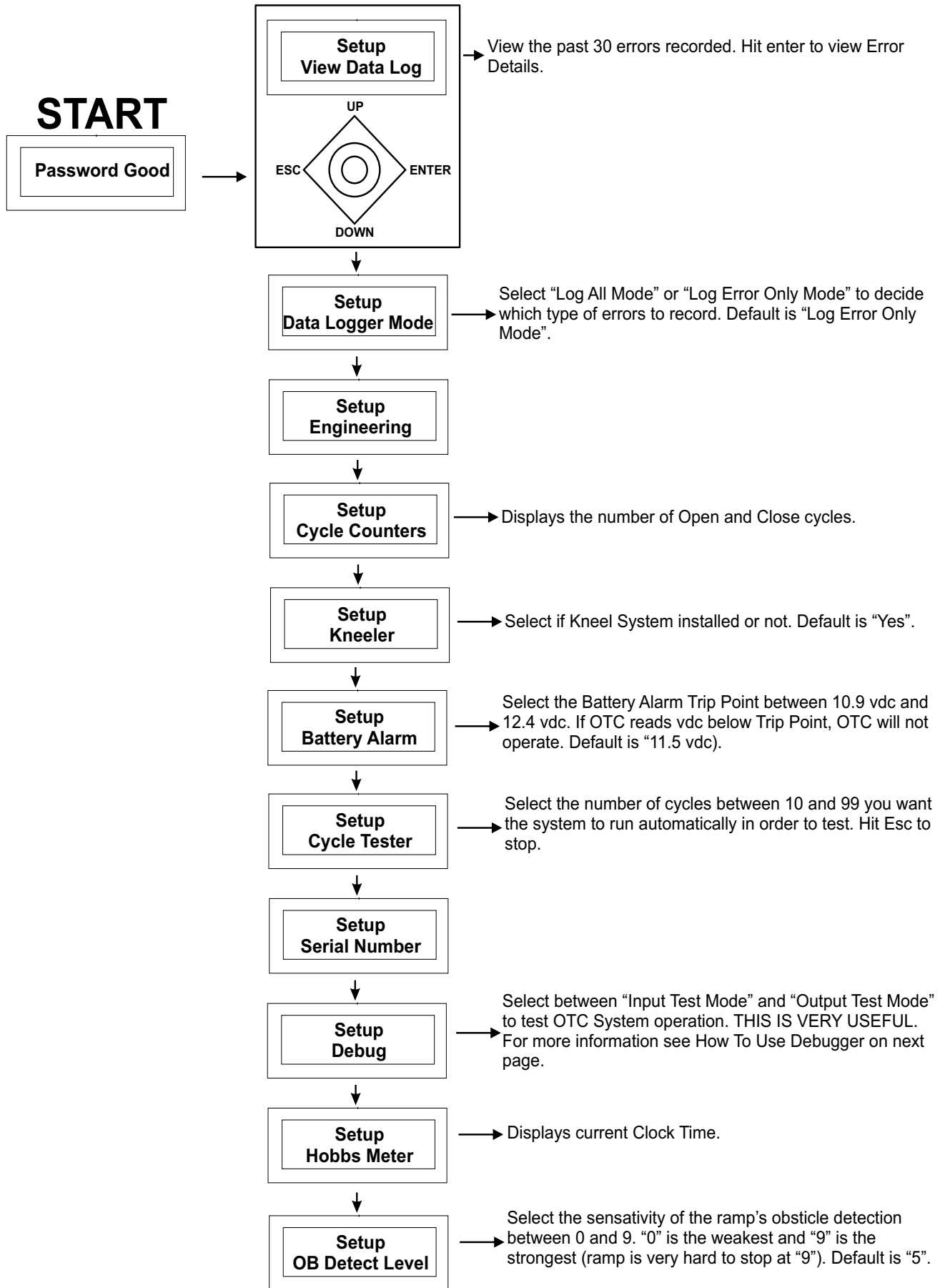



How to Use Debugger (Output Test Mode)

Use extreme caution when using the Output Test Mode. The Output Test Modes sends the signal directly to the OTC Relay Board which results in power going to the called motor. No safeties are in place (ie. The Ramp Down will operate the ramp regardless if the door is open or closed).

START

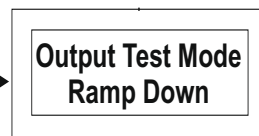
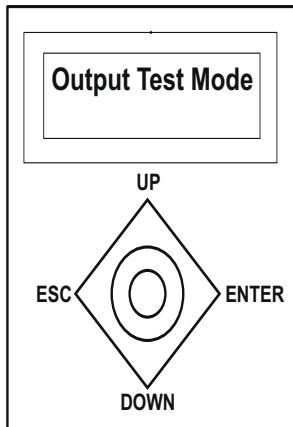

Relay should click and ramp should go out.

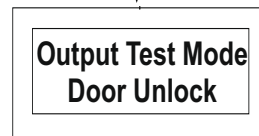

All OEM Doors should unlock.

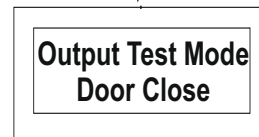

Closes the passenger sliding door.

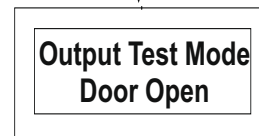

Opens the passenger sliding door.

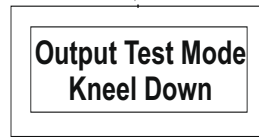

Press and hold to operate the kneeler and lower the van.
Relay should click.



Press and hold to operate the kneeler and raise the van.
Relay should click.

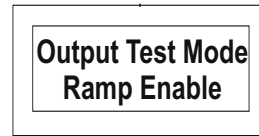

Relay should click.

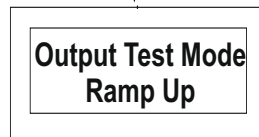

Relay should click and ramp should go out.



How to Use Debugger (Input Test Mode)

The Input Test mode is very useful for testing the various limit switches the systems requires. To operate:

- 1) Select a Limit Switch (Input) you would like to test from the list below.
- 2) Notice if the Switch is "On" or "Off" when it is suppose to be. The audible beeps let you test the switch by hand without looking at the OTC Board.
 - On (activated) = Double Beeps
 - Off (not activated) = Single Beeps

START

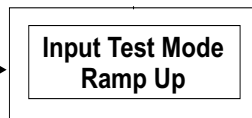
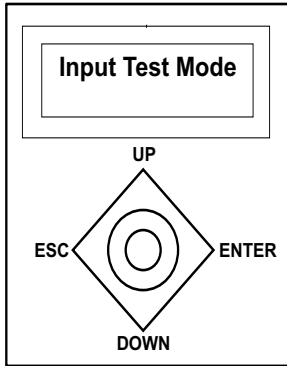

→ ON when ramp is all the way in.

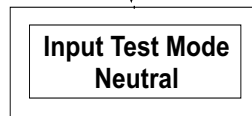

→ ON when van is in Park or Neutral.

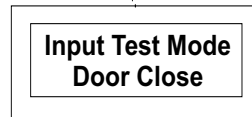

→ ON when passenger sliding door is closed.

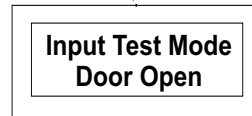

→ ON when passenger sliding door is all the way open.

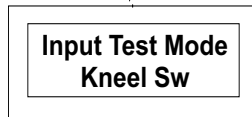

→ ON when Dash Kneel On/Off switch is on.

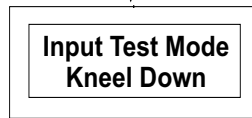

→ ON when kneeler is all the way down (knelt).

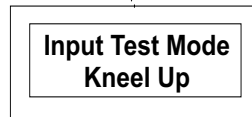

→ ON when kneeler is all the way up (normal).

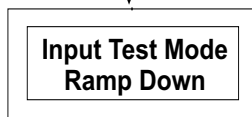

→ ON when ramp is all the way out.



One Touch System - v8.0 Error Codes

For information about OTC Interface and how to use the Debugger, please refer to 'One Touch System - v8.0 Advanced Interface' section. Remember, in Input Test Mode, double beeps indicate the switch is on or activated and single beeps indicate that it is not. Also refer to the 'One Touch System - Relay Board Troubleshooting' for more information about the Relay Board, its Override Switches and LED Indicator Lights.

Code	Description - What Caused the Code
Error 1 - Battery Low Error	Everytime before the OTC cycles, it checks the Main Battery's voltage. If reading is below the value set in the OTC Setup, the OTC will continue to operate, but will indicate a low battery warning. The default value is 11.5 volts.
Diagnostic Tests	More Information
Perform a Draw Test Follow instructions in 'Battery Information - Draw Test Procedure' Section	Rollx Vans recommends starting your van every 4-5 days, allow it to run 15-20 minutes to keep the battery at a sufficient state of charge. A timer is included on the OTC that will shut it off after 5 minutes UNLESS in Setup Mode. Update OTC if needed.



Code	Description - What Caused the Code
<p>Error 11 - Door Control Error</p>	<p>Door Control Output failure (The OTC did not successfully control the door to open or close). The OTC did not receive the signal that the door came off the OEM Door Ajar Switch when opening or did not receive the signal that the door came off the Rollx Vans Door Open Switch when closing. Once the OTC sends the signal to open the door, it waits about 2 seconds to see if the Door Ajar Switch is not activated. If the Door Ajar Switch is still active, this message will appear.</p>
Diagnostic Tests	More Information
<p>Output Test Place OTC in Debug - Output Test Mode to verify OTC operates the door correctly by sending signal to OEM B-Pillar Switch and/or OEM Front Passenger Door Unlock Switch.</p> <ol style="list-style-type: none"> 1) Check Door Open. 2) Check Door Close. 3) Check Door Unlock. 4) Check Ramp Enable. This closes a relay on the OTC Relay Board that enables the ramp to run (prevents the ramp from running if the door is not open, door open enables ramp enable). 	<p>OEM B-Pillar Switch / Door On/Off If off, the OEM Overhead Power Sliding Door On/Off Switch will prevent the door from operating from the OEM B-Pillar Switch. The OTC uses this switch to open or close the door. When off, the OTC can not control the door. Make sure the switch is on and try hitting the OEM B-Pillar switch. If the door still does not work, likely an OEM issue. If OEM function works, but OTC does not check wiring.</p>
<p>Input Test Place OTC in Debug - Input Test Mode to verify limits operate correctly.</p> <ol style="list-style-type: none"> 1) Check Door Open (Rollx Vans Door Open Switch), by opening door all the way in Door Open. 2) Check Door Close (OEM Door Ajar Switch), by close door all the way in Door Close. Rollx Vans taps into OEM Door Ajar Switch in Lower B-Pillar (See OTC Wiring for more information). 	<p>Door Unlock Switch Door must be unlocked to open. First try OEM Unlock Switch in Passenger Front Door. The OTC uses this switch to unlock all the doors before an Door Open Command is sent. If OEM Switch does not unlock doors, likely an OEM issue. If OEM functions, but OTC does not check wiring.</p> <p>Door Ajar Switch If the OEM Door Ajar Switch is not deactivated within 2 seconds of the start of the cycle, Door Control Error will be returned.</p>



Code	Description - What Caused the Code
Error 18 - Ramp Obstacle Detection Error	OTC detected that the ramp may have hit an obstruction on the in or out cycle. The OTC detects an obstruction by measuring the current generated from the ramp motor. The obstruction could be something in the way or a Ramp Limit is not recognized. If this current exceeds the set limit in the OTC Setup (default is 5, scale is 1-10 with 1 being the most sensitive)
Diagnostic Tests	More Information
Check Error Log for multiple Obstacle Detection Errors. If there are many, raise the level in Setup.	Setup - OB Detect Level (default is 5, scale is 1-10 with 1 being the most sensitive)
Input Test Place OTC in Debug - Input Test Mode to verify limits operate correctly. 1) Check Ramp Up [Limit Switch] by operating the ramp with Power Override Switch (ITF Ramp) or manually raising (Folding Ramp). 2) Check Ramp Down [Limit Switch] by operating the ramp with Power Override Switch (ITF Ramp) or manually raising (Folding Ramp).	If a Ramp Limit Switch fails, the Obstacle Detection should activate and cause an error. If the Obstacle Detection does not activate, the Ramp Watchdog Timer should. This will also cause an error (Error 27) and end the cycle.

Code	Description - What Caused the Code
Error 23 - Neutral Status Error	Everytime before the OTC cycles, it checks to make sure the van is in Park. This is for safety and can not be changed.
Diagnostic Tests	More Information
Input Test Place OTC in Debug - Input Test Mode to verify OTC recognizes if the van is in Park correctly 1) Check Neutral by placing the van in and out of Park and listening for the double beeps from the debugger.	Refer to Important Item Information or OTC Wiring Diagram for more information about where Rollx Vans gets this signal.

Code	Description - What Caused the Code
Error 25 - Emergency Stop Error	Anytime a Rollx Vans User or Remote Button is pressed during an open or close cycle, the system will stop immediately. If a Hard Wired User Button is held down long enough, the OTC will think it has been pressed twice and thus, cause an error.
Diagnostic Tests	More Information
Operate User Button to verify working correctly.	This is a safety feature and can not be changed.



Code	Description - What Caused the Code
<p align="center">Error 27 - Ramp Watchdog Error</p>	<p>Once the OTC sends the signal to start running the ramp motor in or out, a timer starts. If enough time passes before the proper limit switch is activated at the end of the cycle, the OTC will return this error. This is a safety feature to limit power to the motor in case of multiple failures.</p>
Diagnostic Tests	More Information
<p>Operate the In-The-Floor ramp with Power Override to help determine if motor and ramp are functioning correctly.</p>	<p>Not available on Folding Ramps.</p>
<p>Output Test Place OTC in Debug - Output Test Mode to verify OTC operates the ramp motor correctly. 1) Check Ramp Open. 2) Check Ramp Close.</p>	<p>Several factors such as low battery, cold weather or debris can prevent the motor from operating correctly. If low battery, very cold or a bad motor, the motor may run too slow causing this watchdog to activate. Debris can also prevent the motor or ramp operating at correct speed, also causing this error.</p>
<p>Input Test Place OTC in Debug - Input Test Mode to verify limits operate correctly. 1) Check Ramp Up [Limit Switch] by operating the ramp with Power Override Switch (ITF Ramp) or manually raising (Folding Ramp). 2) Check Ramp Down [Limit Switch] by operating the ramp with Power Override Switch (ITF Ramp) or manually raising (Folding Ramp).</p>	<p>If a Ramp Limit Switch fails, the Obstacle Detection should activate and cause an error (Error 18). If the Obstacle Detection does not activate, the Ramp Watchdog Timer should. This will also cause an error.</p> <p>If OTC Debug Output Test does not activate the motor being tested, try the overrides located on the OTC Relay Board. This will indicate a communication problem between the One Touch Controller and One Touch Relay Board.</p>



Code	Description - What Caused the Code
Error 28 - Door Watchdog Error	Once the OTC sends the signal to operate the OEM Door, a timer starts. If enough time passes before the proper limit switch is activated at the end of the cycle, the OTC will return this error.
Diagnostic Tests	More Information
Operate the OEM Door with the OEM B-Pillar Switch to determine if OEM Door is functioning properly.	If OEM B-Pillar Switch is not working, try the OEM Overhead Door Switch and make sure the OEM Overhead Door On/Off Switch is on.
Input Test Place OTC in Debug - Input Test Mode to verify limits operate correctly. 1) Check Door Open (Rollx Vans Door Open Switch), by opening door all the way in Door Open. 2) Check Door Close (OEM Door Ajar Switch), by close door all the way in Door Close. Rollx Vans taps into OEM Door Ajar Switch in Lower B-Pillar (See OTC Wiring for more information).	If Door Limits function correctly and door cycles open and close okay, the issue is with the door taking too long to open or close. Check alignment or motor.
Output Test Place OTC in Debug - Output Test Mode to verify OTC operates the door correctly by sending signal to OEM B-Pillar Switch and/or OEM Front Passenger Door Unlock Switch. 1) Check Door Open. 2) Check Door Close.	If an Output is an issue, the Door Control Error (Error 11) will likely display.

Code	Description - What Caused the Code
Error 29 - Kneeler Watchdog Error	Once the OTC sends the signal to operate the Kneeler, a timer starts. If enough time passes before the proper limit switch is activated at the end of the cycle, the OTC will return this error.
Diagnostic Tests	More Information
Operate the Kneeler with Power Override to help determine if motor is functioning correctly.	Reset - Esc - Kneel Up/Kneel Down
Input Test Place OTC in Debug - Input Test Mode to verify limits operate correctly. 1) Check Kneel Up [Limit Switch], by raising Kneeler until switch is activated or activate switch by hand. 2) Check Kneel Down [Limit Switch], by Lowering Kneeler until switch is activated or activate switch by hand.	Testing with Power Override is preferred since it will indicate if Limit Switch is being properly activated by Actuator's Guide. When Kneel Actuator reaches its run limit, it will begin to ratchet making a terrible sound. This is simply the motor's clutch mechanism, is not damaging but should try and be minimized.
Output Test Place OTC in Debug - Output Test Mode to verify OTC operates the Kneeler correctly. 1) Check Kneel Up. 2) Check Kneel Down.	If OTC Debug Output Test does not activate the motor being tested, try the overrides located on the OTC Relay Board. This will indicate a communication problem between the One Touch Controller and One Touch Relay Board. Also a low battery, bad motor or cold weather causing the motor to run very slowly can return this error.



Code	Description - What Caused the Code
<p>Error 33 - Door Ajar Error</p>	<p>The OTC will not run a Cycle if the door is Ajar (Not fully opened or closed). If Ramp deployed, open door fully. If ramp stowed, fully close and latch door.</p>
Diagnostic Tests	More Information
<p>Operate the OEM Door with the OEM B-Pillar Switch to determine if OEM Door is functioning properly.</p>	<p>If OEM B-Pillar Switch is not working, try the OEM Overhead Door Switch and make sure the OEM Overhead Door On/Off Switch is on.</p>
<p>Input Test Place OTC in Debug - Input Test Mode to verify limits operate correctly.</p> <ol style="list-style-type: none"> 1) Check Door Open (Rollx Vans Door Open Switch), by opening door all the way in Door Open. 2) Check Door Close (OEM Door Ajar Switch), by close door all the way in Door Close. Rollx Vans taps into OEM Door Ajar Switch in Lower B-Pillar (See OTC Wiring for more information). 	



**RELAY BD OTC VERSION 2
P.N. 08044-002
ORDER #OTCV8 RELAY BD**

OUTPUTS

Run to the Kneeler and Ramp Motors

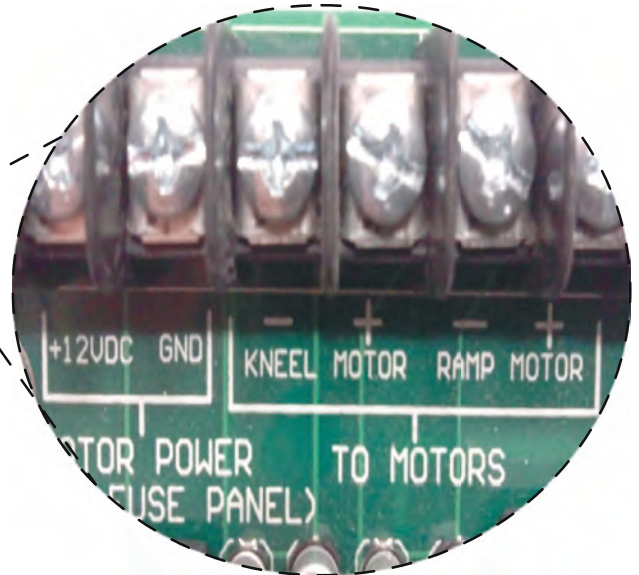
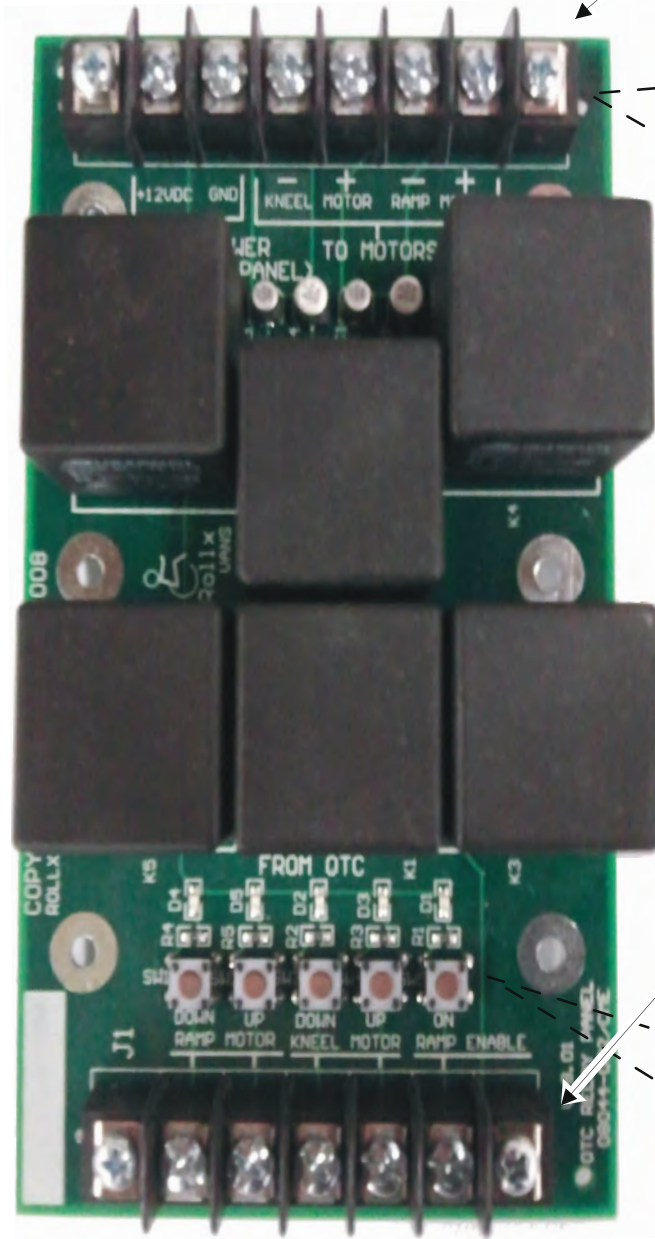

INPUTS

Run from the OTC Control Board

LED Indicator Lights

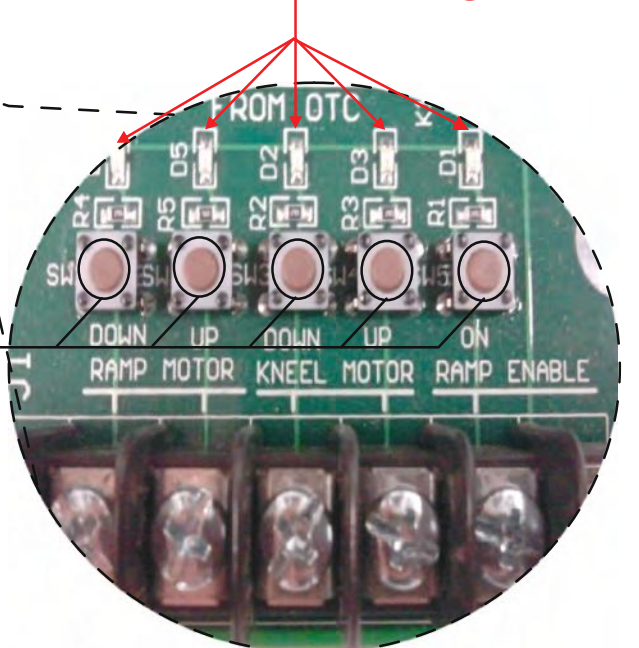

Manual push button test switches

*Pressing the switches should operate each function as shown on the board as long as the board is working properly. Remember, to run the ramp, the Ramp Enable must also be pressed at the same time. Pressing a switch is the same as sending a ground to the terminal.



Symptom	Possible Cause	Remedy
Ramp will NOT DEPLOY after door opens automatically.	Door detector failure.	When a Open Cycle starts, the OTC will send a command to the Honda System to unlock the doors. It then sends a second command to the Honda System to open the Right Side Sliding Door. The OTC Computer then waits two seconds and checks the Door Closed Limit Switch. If it finds it still indicates the door is closed, it assumes that a person (or and obstacle) stopped the door opening sequence. It then ends the open cycle and goes back into Idle Mode. After ten to fifteen seconds it goes back into Sleep Mode. Once the OTC knows the door has begun to open, the Door Detector counts the pulses from the door motor to indicate how far open the door is. Once enough pulses have been received the Door Detector thinks the door is open all the way and send the signal to deploy the ramp. See Door Detector Section for more information.
	Ramp motor not engaged.	Engage ramp motor. Refer to the "Manual Operation" section of this manual.
	Ramp down limit switch needs adjustment to deactivate.	Press Rollx Vans user button again to unkneel van and close door. Review display on OTC board and contact customer service.
	Ramp motor.	Review display on OTC board and contact customer service.
Ramp will NOT STOW automatically.	OTC program failure.	Press OTC reset button.
	OTC was reset or was inactive for too long with ramp out.	Stow ramp with power override and close door manually. Reset OTC.
	Ramp motor not engaged.	Engage ramp motor by making sure ramp motor release is turned all the way clockwise.
	Ramp motor.	Test operation of motor using power override.
	Low voltage from the battery.	Start vehicle or charge battery. Press OTC reset button and press Rollx Vans user button again.
Door does not open ALL the way. (Door "relaxes" closed slightly so the ramp might hit the door when it deploys.)	Door open latch failure.	Try running system again.
Ramp will deploy before door is all the way open.	Door detector failure.	Try running system again. See Door detector section above.
Ramp will STOP AND REVERSE mid-cycle.	Obstacle is detected.	Clear obstruction and press Rollx Vans user button.
		Review display on OTC board and contact customer service.
Ramp will start to deploy or stow then stop functioning.	Pressure on cover plate.	Ensure that there are no objects on top of cover plate.

Item	Qty.	Description	Part #
17	1	RAMP ITF ASM	N005001ASM
18	2	5/16-18X2 SIS FHSCS	1173912
19	1	TRACK FLOOR PLATE FRONT ASM	H05017ASM
20	1	TRACK FLOOR PLATE REAR ASM	H05016ASM
21	1	TRACK EXTENSION LOWER HONDA	H05071
22	1	ALUMINUM UNTHREADED (ACTIVATOR)	92510A351
23	2	PRECISION MINATURE IDLER	2483K18
24	1	ROLLER PLATE 2011, HONDA	H05003ASM
26	1	CONN LINK #35 CARBON	CHRLCL035
27	1	LOCKING HOLE & VENT	24412
28	4	SS TORX BHCS 1/4-20	10929-02112
30	4	1/4 USS F/W Z	1133004
31	2	TEFLON BLOCK FOR ITF RAMP	H11049
32	4	RIVETS	97517A130
33	2	SPACER ROLLER CUSHIONED	N05048
34	1	TRACK LOWER ROLLER PLATE D.S	H05083-D
35	1	TRACK LOWER ROLLER PLATE P.S	H05083-P
36	1	CARPET TRIM FRONT	N05021GF
37	1	CARPET TRIM BACK	N05021G-B
38	1	RAMP LIMIT SWITCH BRACKET (use w/It N08111ASM)	N05039
39	1	DOOR TRACK DRIVER ITF	H11025
40	1	DOOR TRACK PASSENGER ITF	H11026

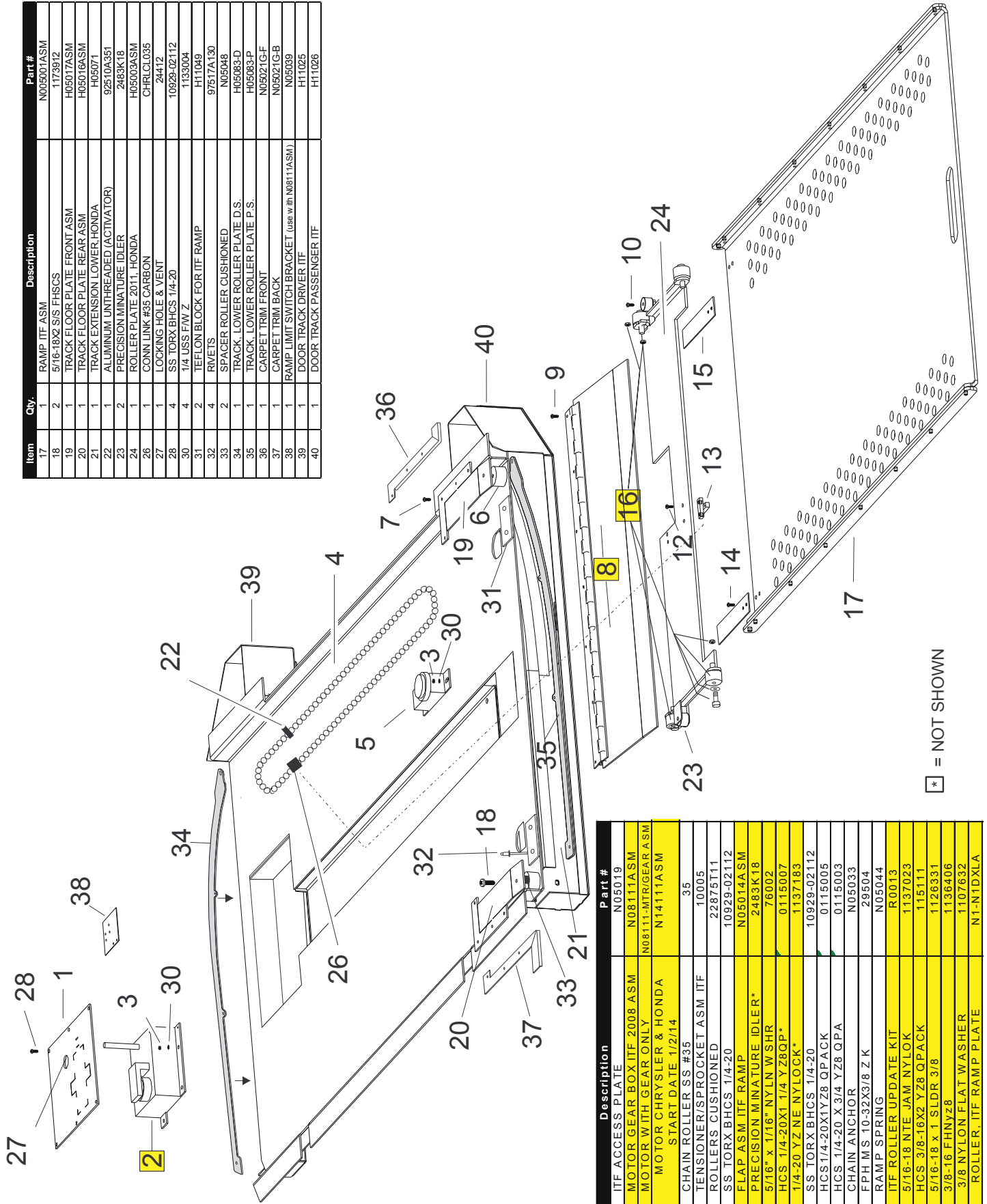

[*] = NOT SHOWN

Item	Qty.	Description	Part #
1	1	ITF ACCESS PLATE	N05019
2	1	MOTOR GEAR BOX ITF 2008 ASM	N08111ASM
*	1	MOTOR WITH GEAR ONLY	N08111-MTR/GEAR ASM
2	1	MOTOR CHRYSLER & HONDA START DATE 1/2/14	N14111ASM
4	10	CHAIN ROLLER SS #35	35
5	1	TENSIONER/SPROCKET ASM ITF	10005
6	2	ROLLERS CUSHIONED	22875T11
7	8	SS TORX BHCS 1/4-20	10929-02112
8	1	FLAP ASM ITF RAMP	N05014ASM
*	3	PRECISION MINATURE IDLER*	2483K18
*	3	5/16" x 1/16" NYLN W/SHR	76002
*	3	HCS 1/4-20X1 1/4 YZ80P*	0115007
*	3	1/4-20 YZ NE NYLOCK*	1137183
9	7	SS TORX BHCS 1/4-20	10929-02112
10	2	HCS 1/4-20X1Y28 QPACK	0115005
12	2	HCS 1/4-20 X 3/4 Y28 QPA	0115003
13	1	CHAIN ANCHOR	N05033
14	4	FPH MS 10-32X3/8 Z K	29504
15	2	RAMP SPRING	N05044
16	1	ITF ROLLER UPDATE KIT	R0013
*	4	5/16-18 NTE JAM NYLON	1137023
*	2	HCS 3/8-16X2 YZ8 QPACK	115111
*	2	5/16-18 x 1 SLDR 3/8	1126331
*	4	3/8-16 FHNZY8	1136406
*	8	3/8 NYLON FLAT WASHER	1107632
*	4	ROLLER ITF RAMP PLATE	N1-NTDXLA



ITF Ramp Motor Removal

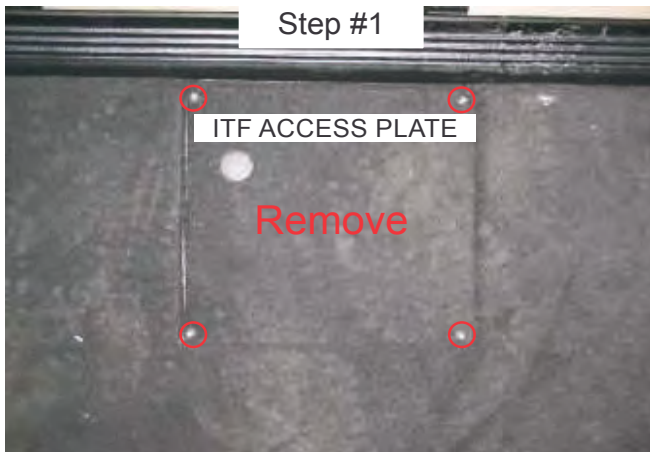

- ** With the ramp in and passenger slider door open.
- A) Remove the 4 bolts securing the ITF motor access plate using: **T27 torx bit.**

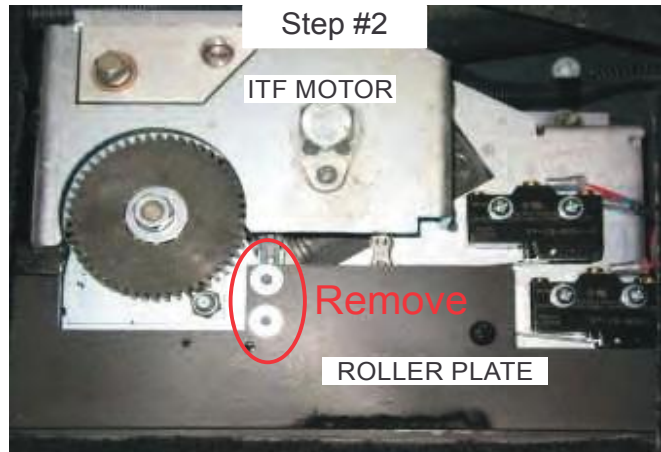

- A) Remove the 2 allen bolts that attach the roller plate to the chain anchor using a **5/32" allen bit.**

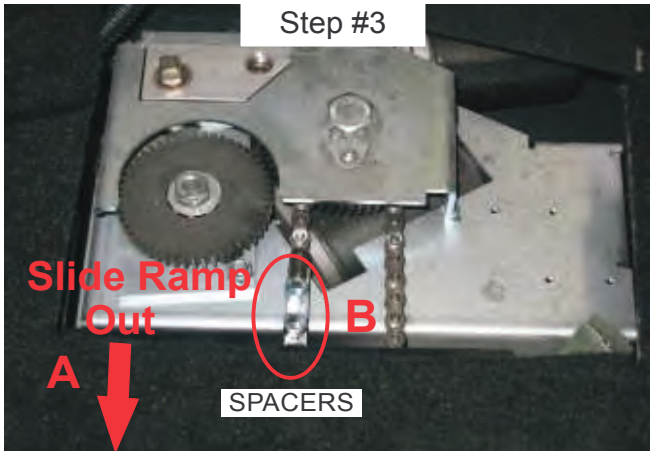

- A) Lift up on the roller plate and slide the ramp out slightly to gain access to the chain anchor.
- B) Remove spacers (set aside).

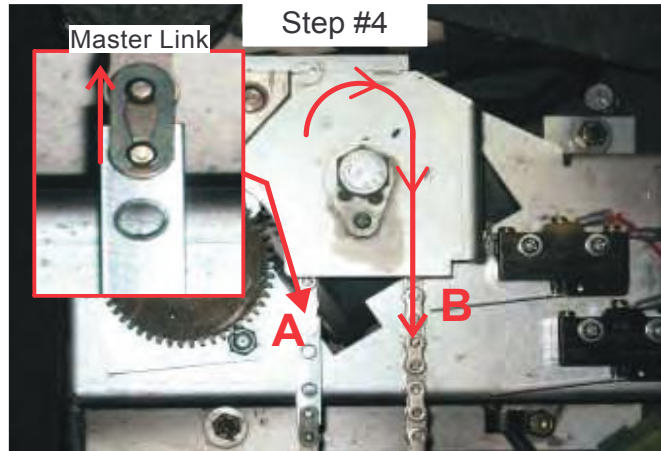

- A) Remove the master link closest to the gear, then disconnect the anchor from the chain.
- B) Pull the chain out of the motor housing.

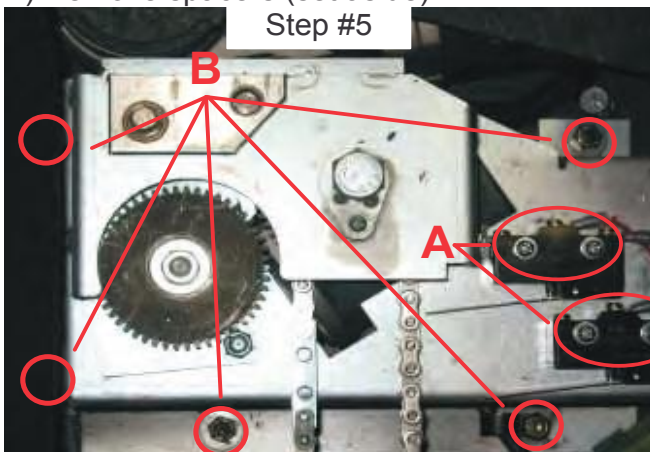

- A) Remove the 4 limit switch screws and remove switches from motor housing.
- B) Remove the (5) 1/4" mounting nuts for the motor using a **7/16" socket w/ extension.**

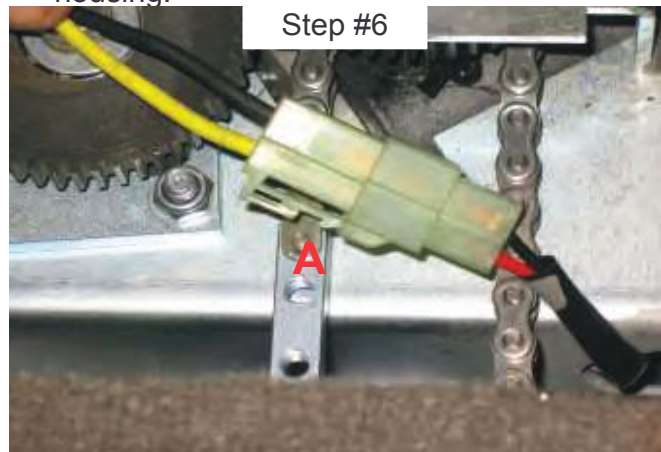

- A) Unplug the connector for the motor and remove motor from van.

*Install new motor in reverse order.



This Page Is Intentionally Left Blank

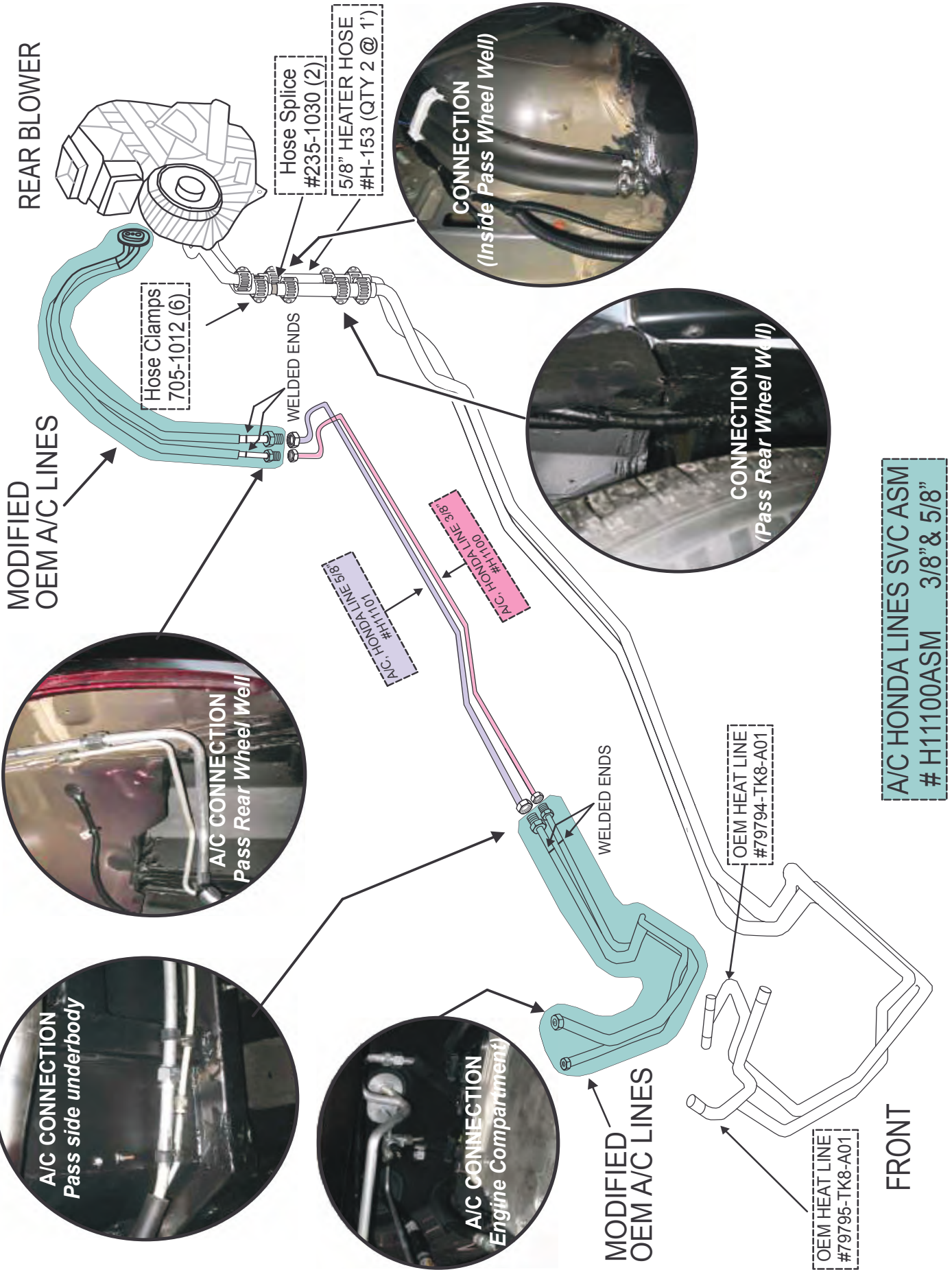



Remote System Troubleshooting

* If remote does not work first try to operate door and ramp from any interior Rollx Vans user button. If interior Rollx Vans user button operates normally, see below for remote system troubleshooting

Symptom	Possible Cause	Remedy
Door does not open when One Touch remote is pressed.	Receiver out of range.	Try remote within 10 feet of van.
	Sliding Door on/off switch located on left dash is turned to the OFF position.	Turn switch to ON position.
	Remote battery is dead (No blue LED light.)	Remove case by loosening screw on back and prying open. Replace batteries with battery type CR2016. Make sure metal tabs are tight holding the battery. Use second remote or Rollx Vans user button.
	Remote lost its program	Reprogram (relearn) remote with receiver.
Neither One Touch remote works.	No Power to receiver (LED light does not light up if button held for 3 seconds.)	Check 1 Amp fuse in Rollx Vans Fuse Holder located under glove box. If that is okay, check connections.
	Receiver malfunction.	Review display on OTC board and contact customer service.



Compustar 6200

OTC Remote Receiver
(Behind Rear Passenger Quarter
Panel Above OTC Relay Board)



OTC Remote Receiver
(Rear View)

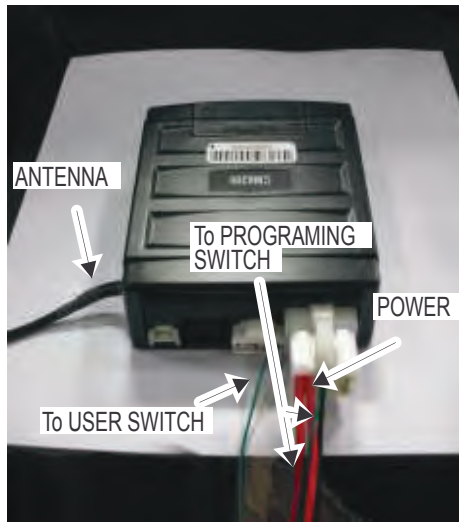

OTC Remote Transmitter

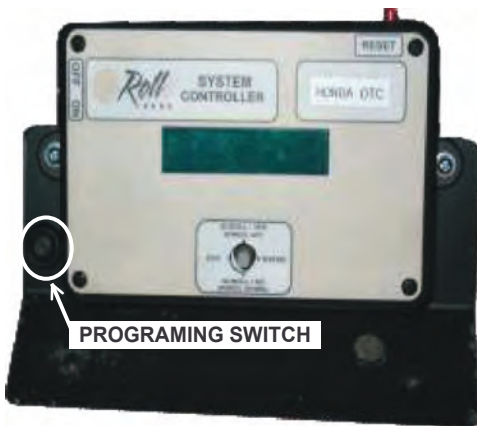

To Rollx Vans user switches

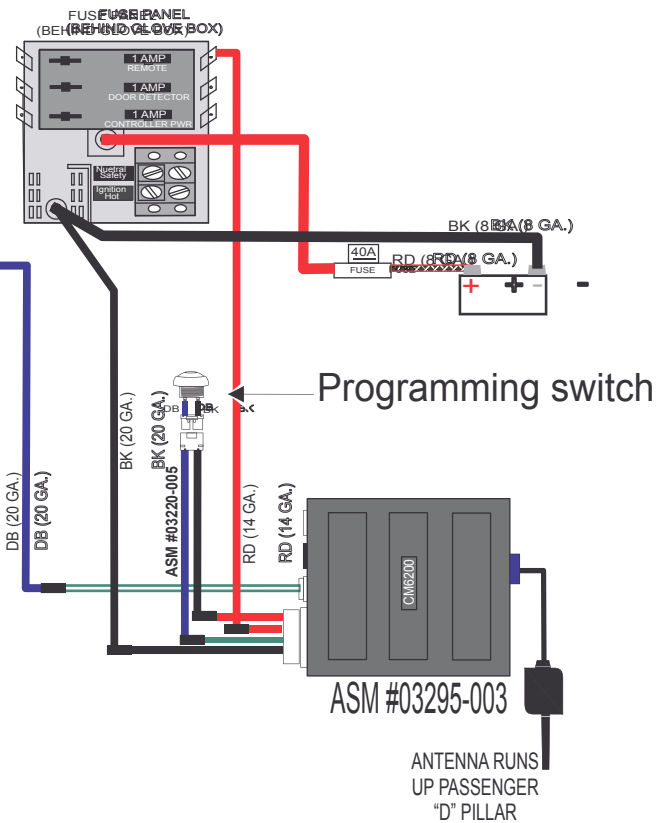

Programming the Rollx Vans OTC Remote

- *Shut off the OTC controller
- *Activate the programming mode by pushing the button on the left side of the OTC controller (PROGRAMMING SWITCH) 5 times within 7 seconds.
- * Within 2 seconds after pushing the button 5 times, press the single remote button for 5



Compustar 7200 with Flashing Lights

OTC Remote Receiver
(Behind Rear Passenger Quarter
Panel Above OTC Relay Board)



OTC Remote Receiver
(Rear View)

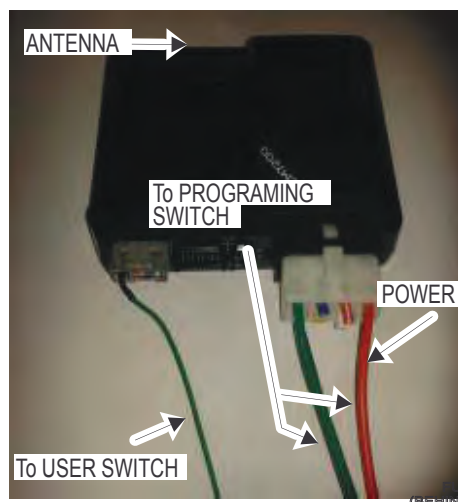

OTC Remote Transmitter

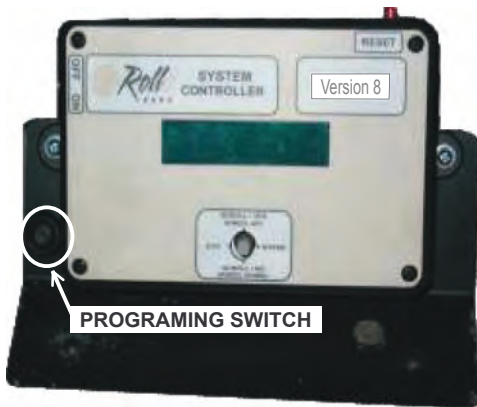

To Rollx Vans user switches

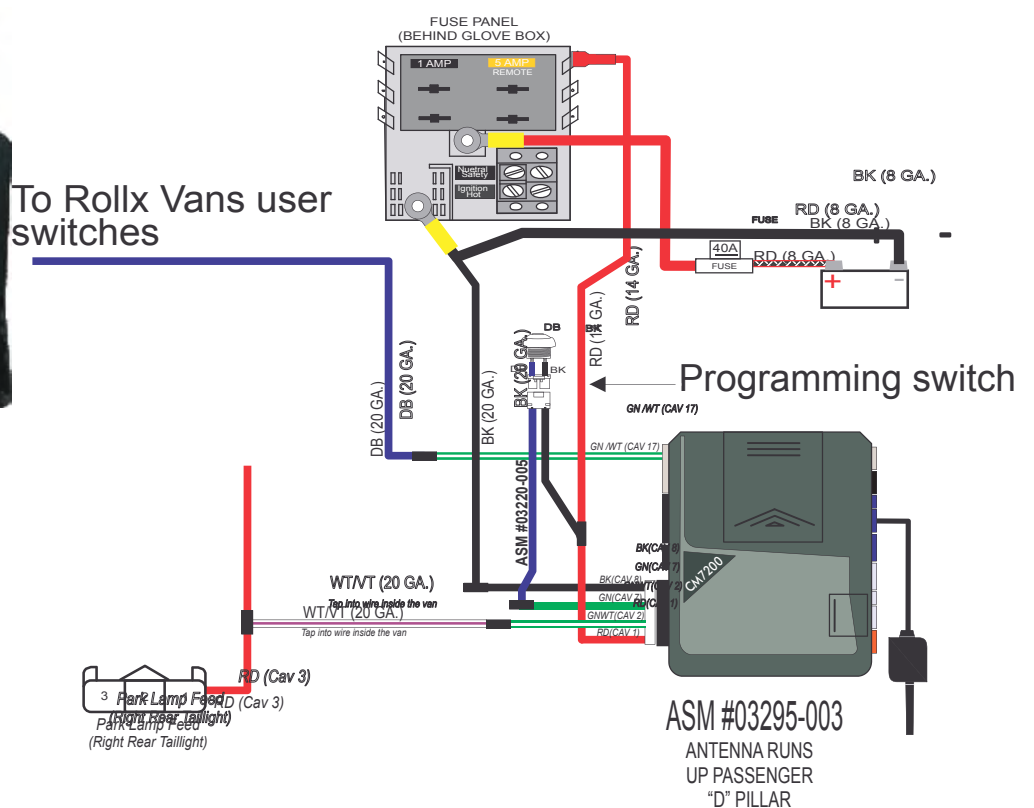

Programming the Rollx Vans OTC Remote

- *Shut off the OTC controller
- *Activate the programming mode by pushing the button on the left side of the OTC controller (PROGRAMMING SWITCH) 5 times within 7 seconds.
- * Within 2 seconds after pushing the button 5 times, press the single remote button for .5 Seconds. Wait 30 seconds and press the remote to operate the system.
- *Repeat the sequence if programming an additional remote.



7/15/2015

2011-2013 Honda Odyssey Minivan Passenger Seat C651 MANUAL Body Side

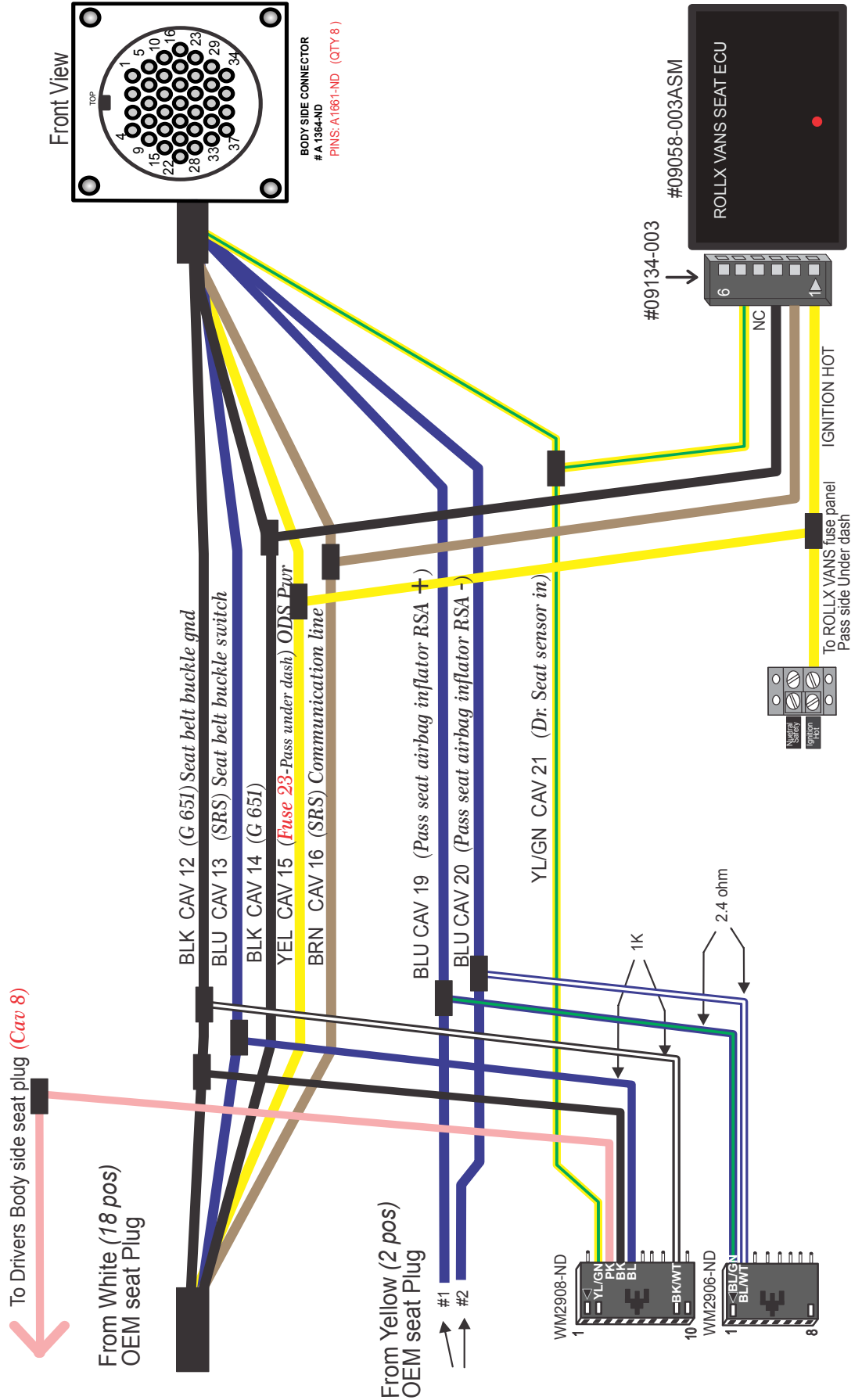

2011-2013 Honda Odyssey Minivan Passenger Seat C651 MANUAL Seat Side

6/2/2014

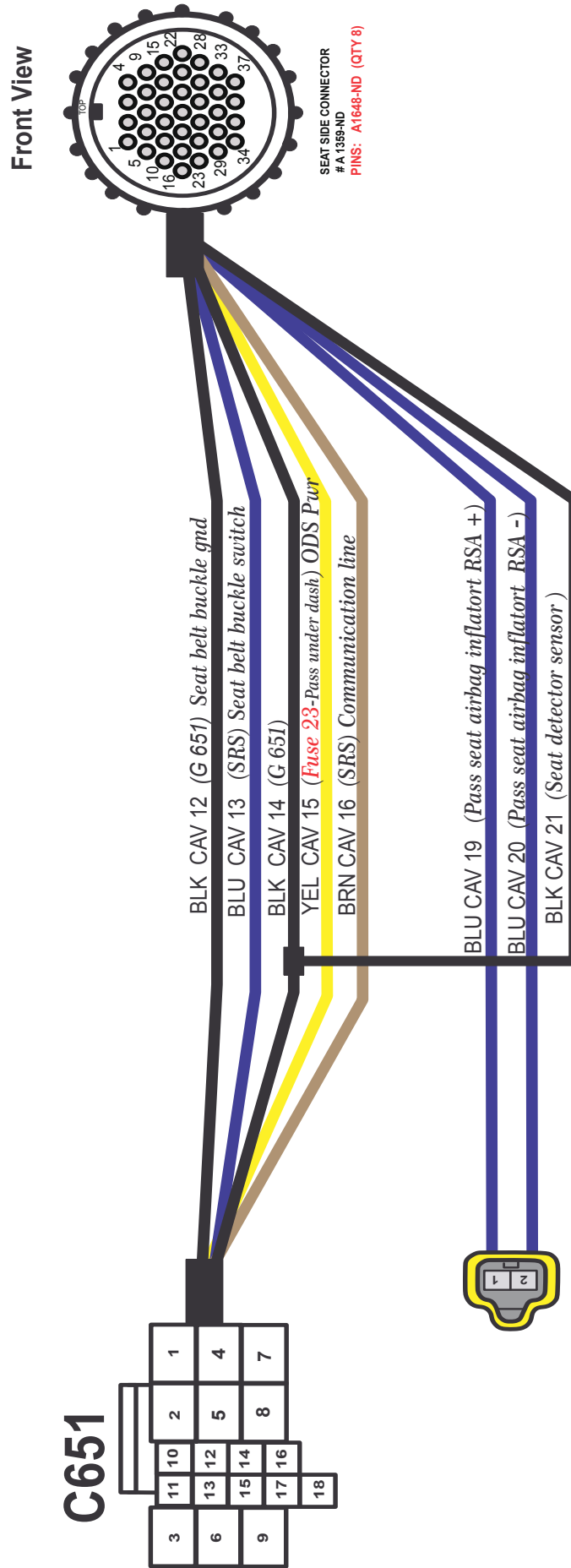



2011-2013 Honda Odyssey Minivan Passenger Seat C651 H.S.M.

Relocated Body Side

7/15/2015



Heated Seat Module
(Mounted on passengers side Z)

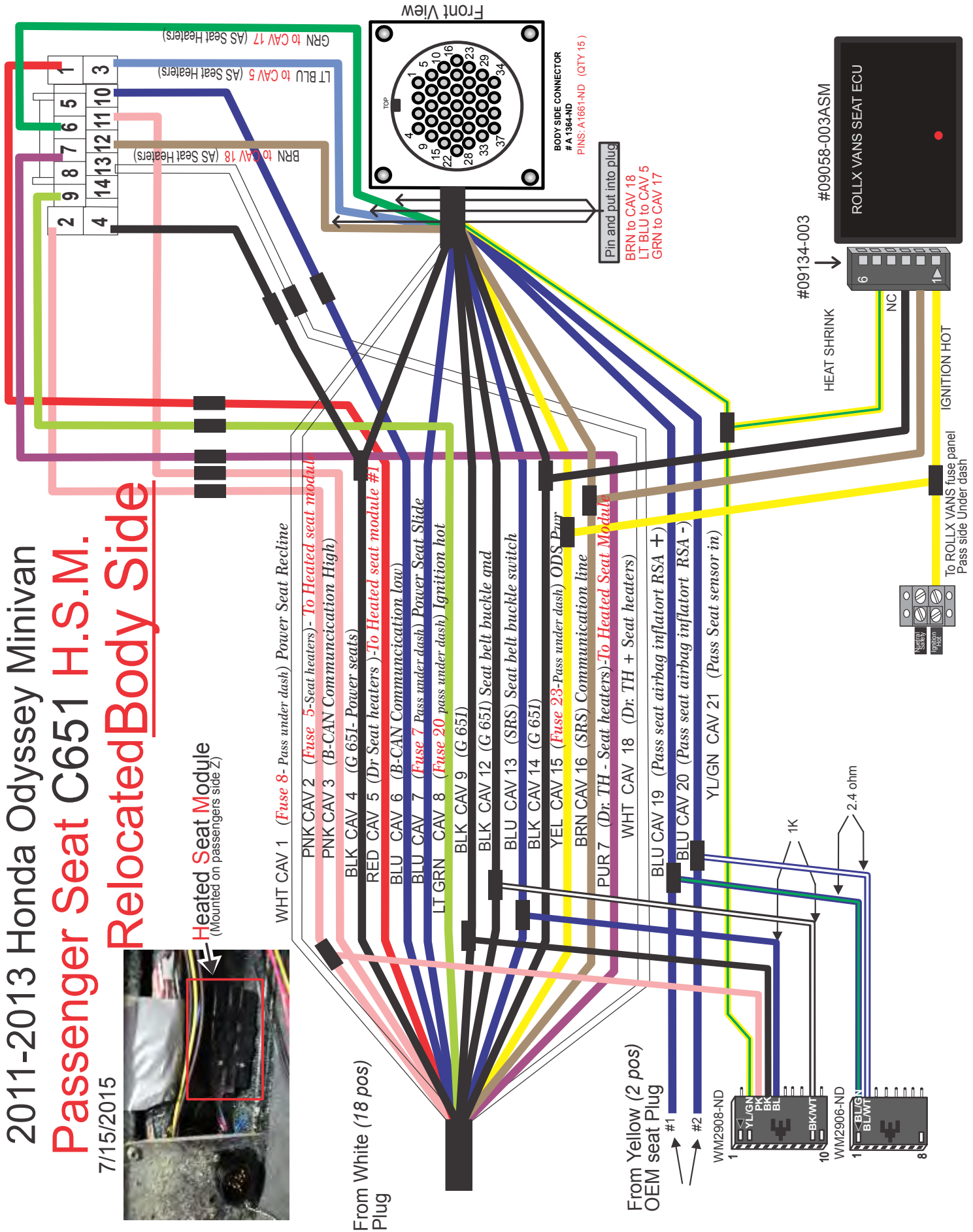

2011-2013 Honda Odyssey Minivan Passenger Seat C651 H.S.M Relocated #09218-001 Seat Side

6/2/2014

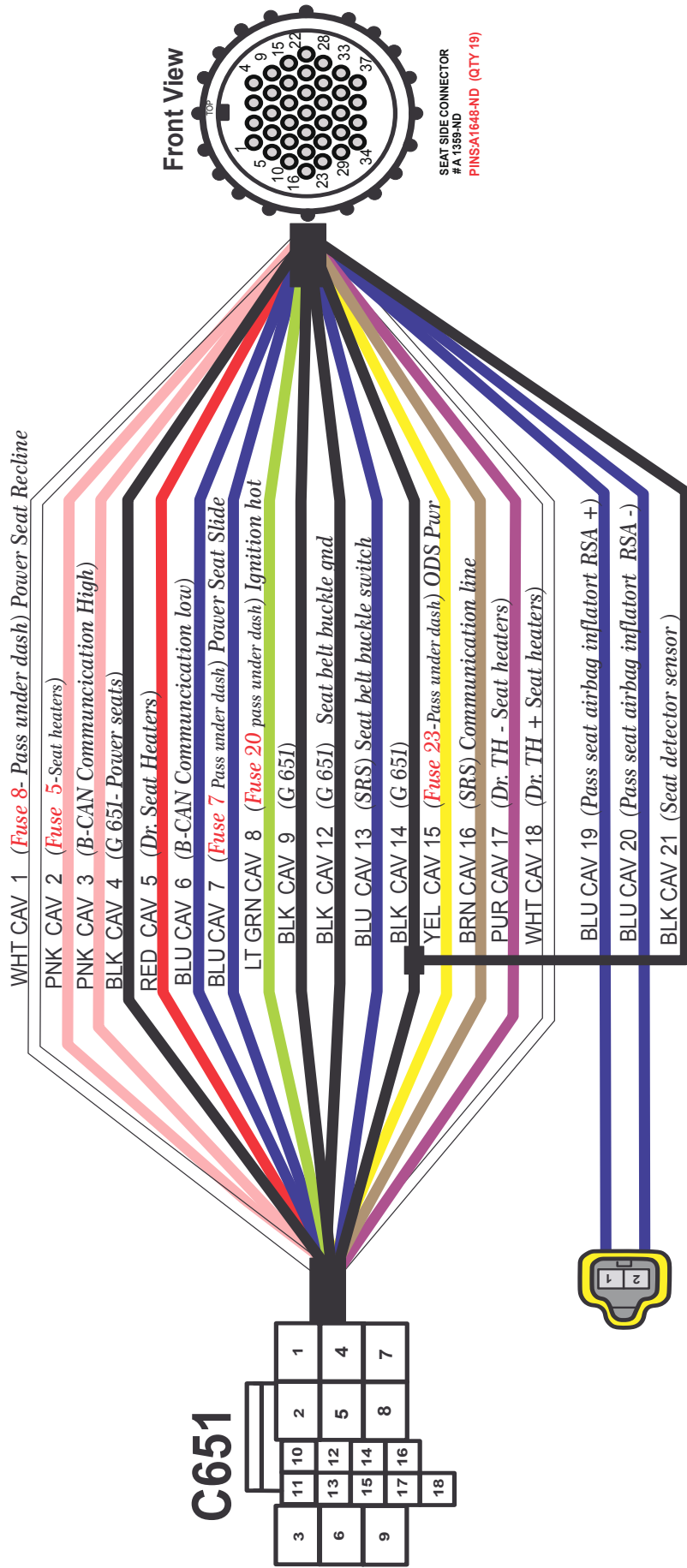

Wiring under passenger's power seat



Harness under passenger's seat

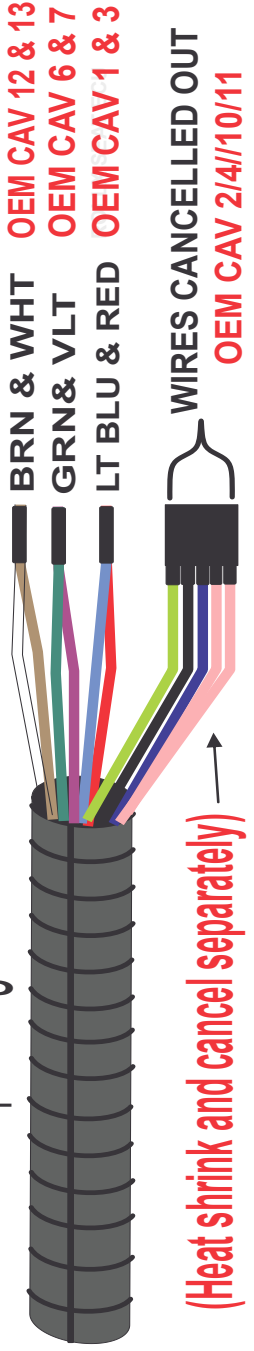

7/15/2015

2011-2013 Honda Odyssey Minivan Driver Seat C601 No DPMS W/ Heat Body Side

For Pass Side MANUAL SEAT. Extend to the pass side
seat detector power wire

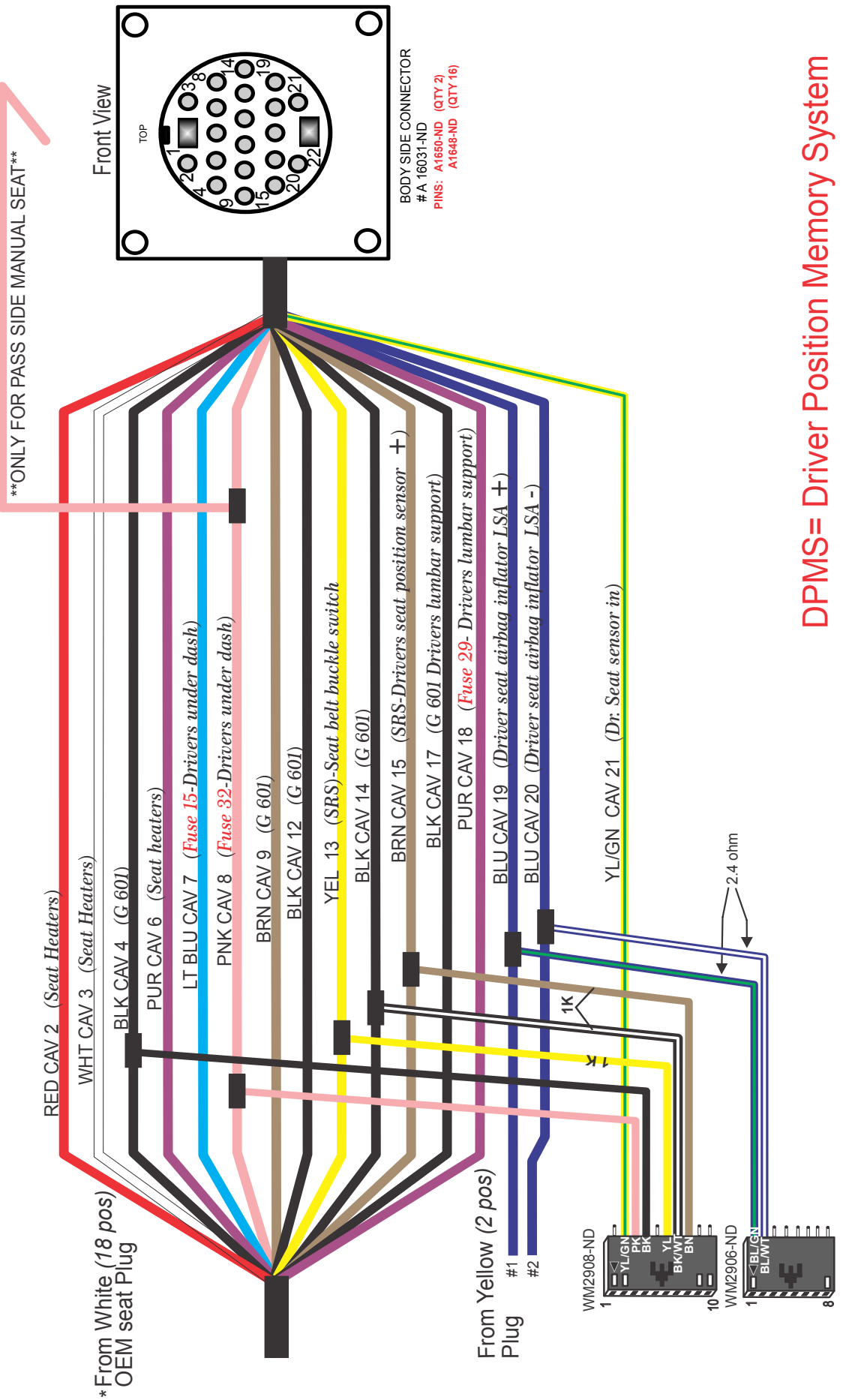

DPMS= Driver Position Memory System



2011-2013 Honda Odyssey Minivan 6/2/2014

Driver Seat C601 No DPMS W/ Heat #09220-001

Seat Side



Driver Seat C601 With DPMS W/ Heat Body Side

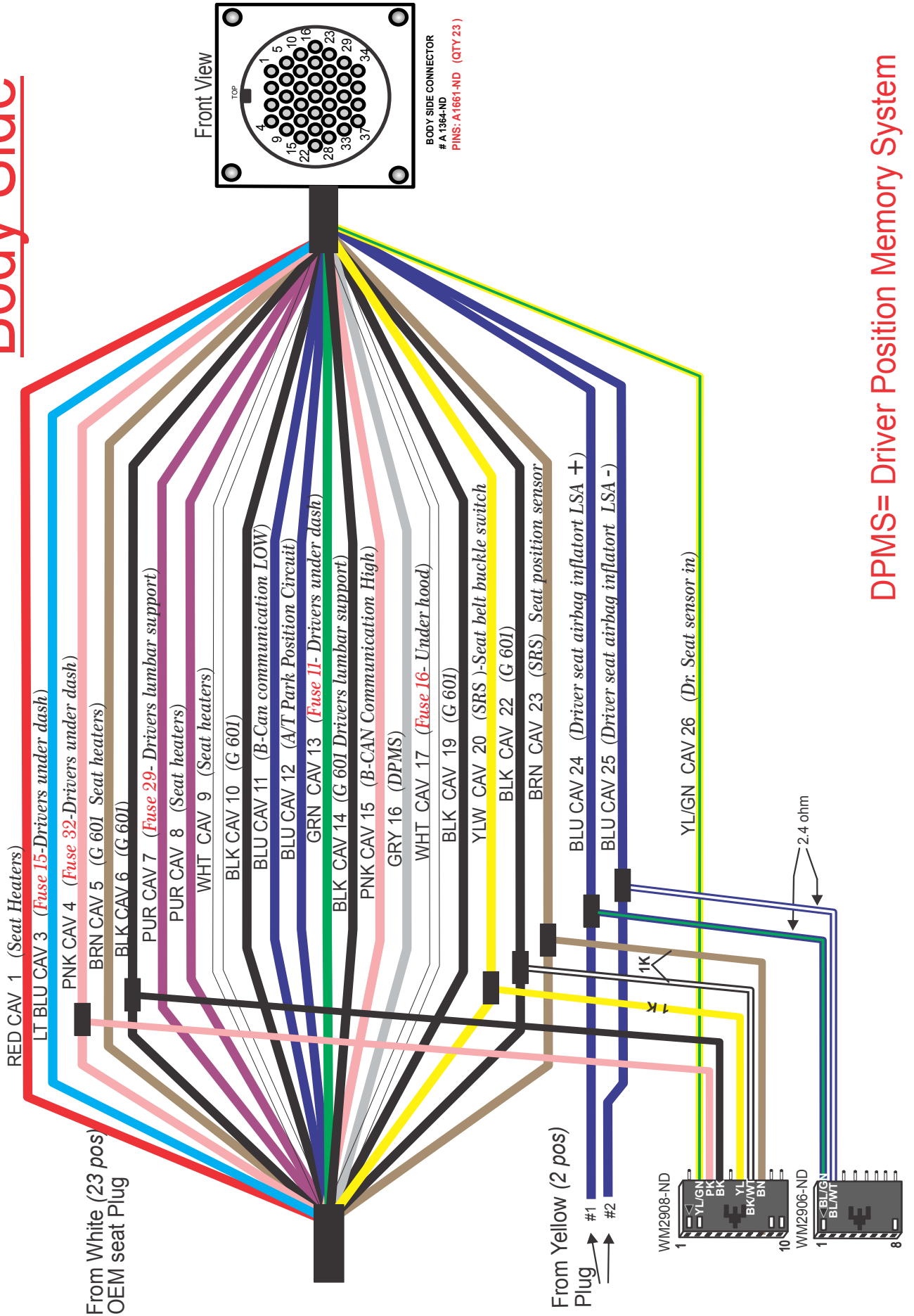

DPMS= Driver Position Memory System

Driver Seat C601 With DPMS W/ Heat #09219-001

Seat Side

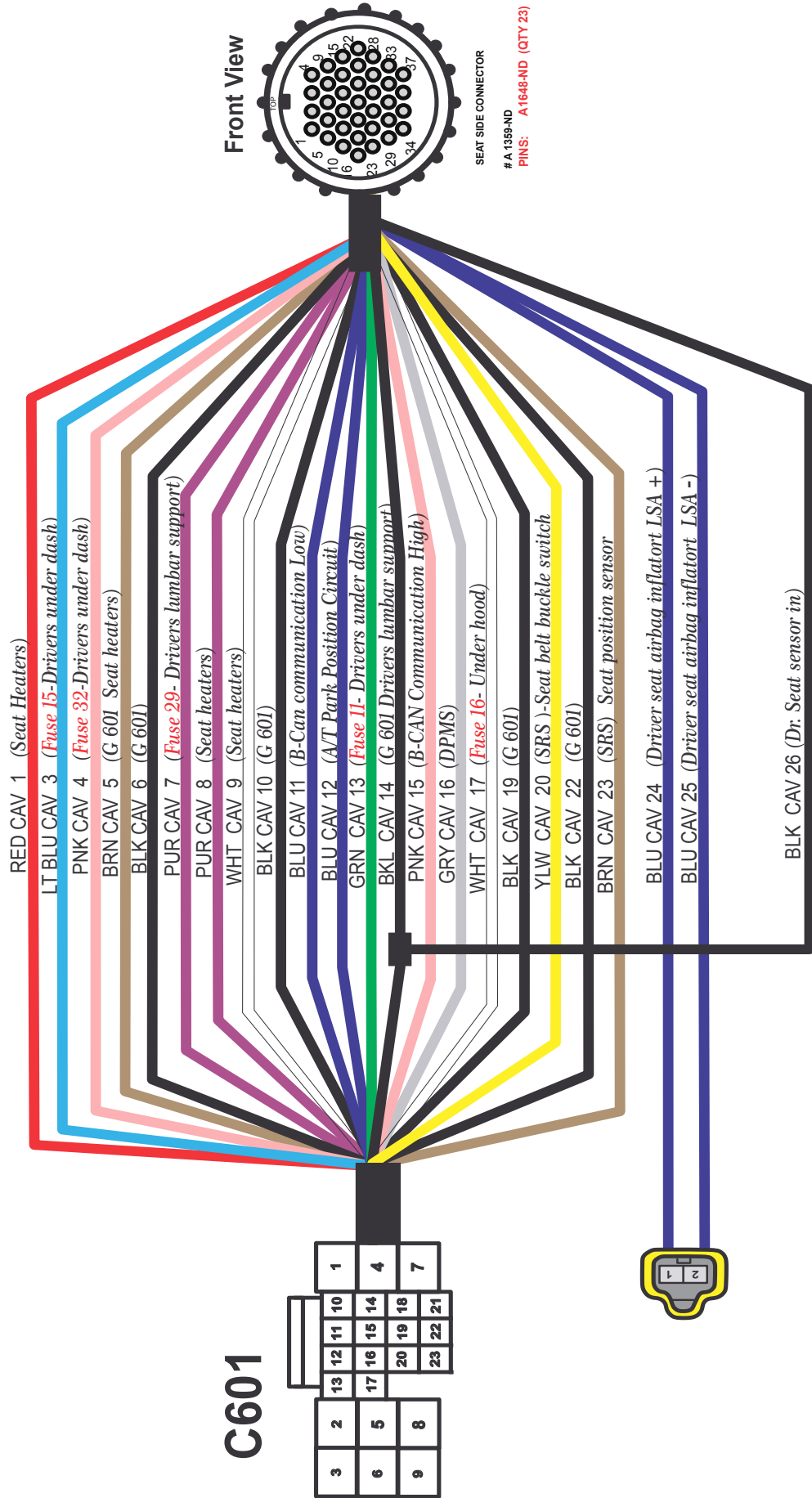



7/15/2015

2014-2016 Honda Odyssey Minivan Passenger Seat C651 Manual Body Side

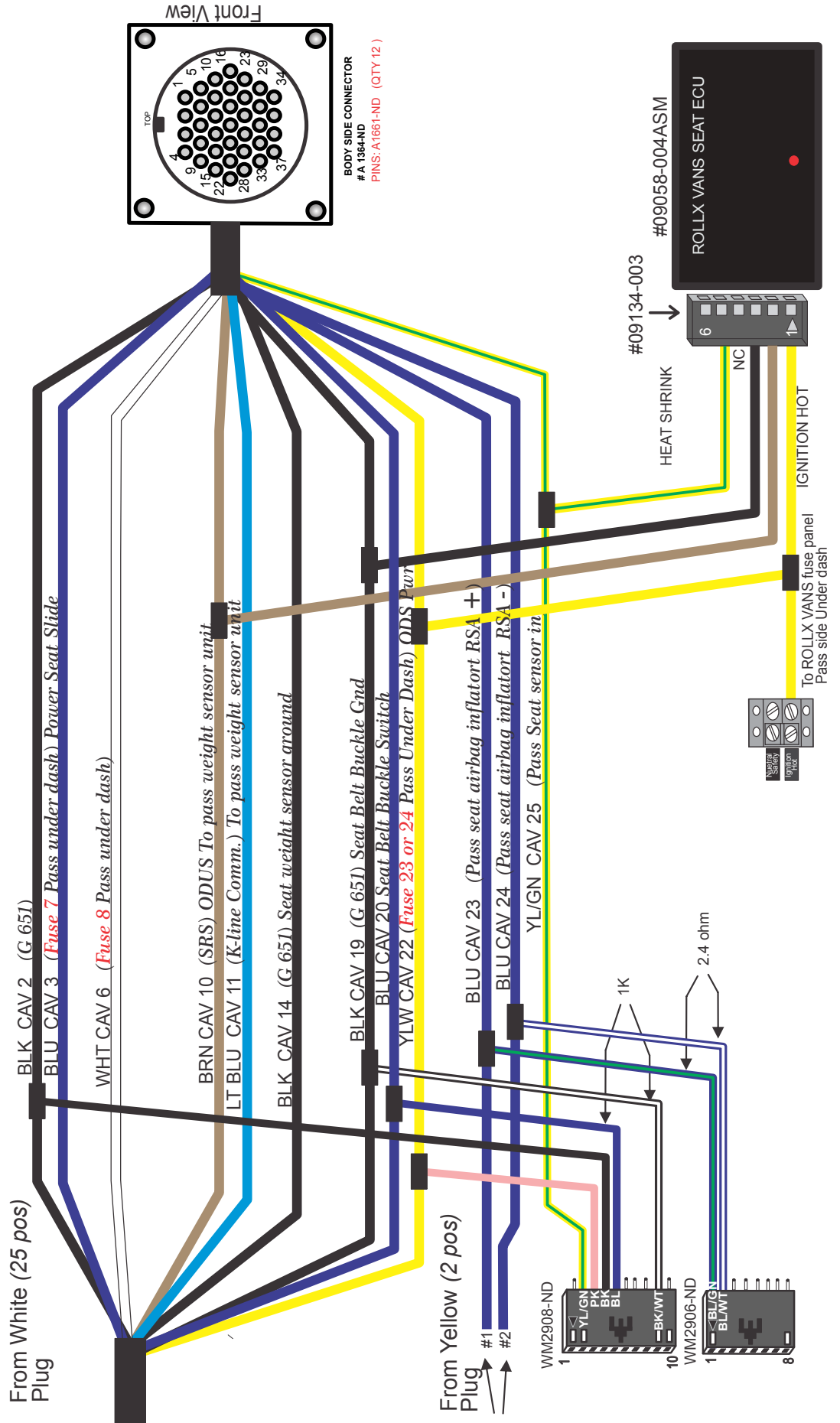

2014-2016 Honda Odyssey Minivan Passenger Seat C651 Manual Seat Side

9/21/2015

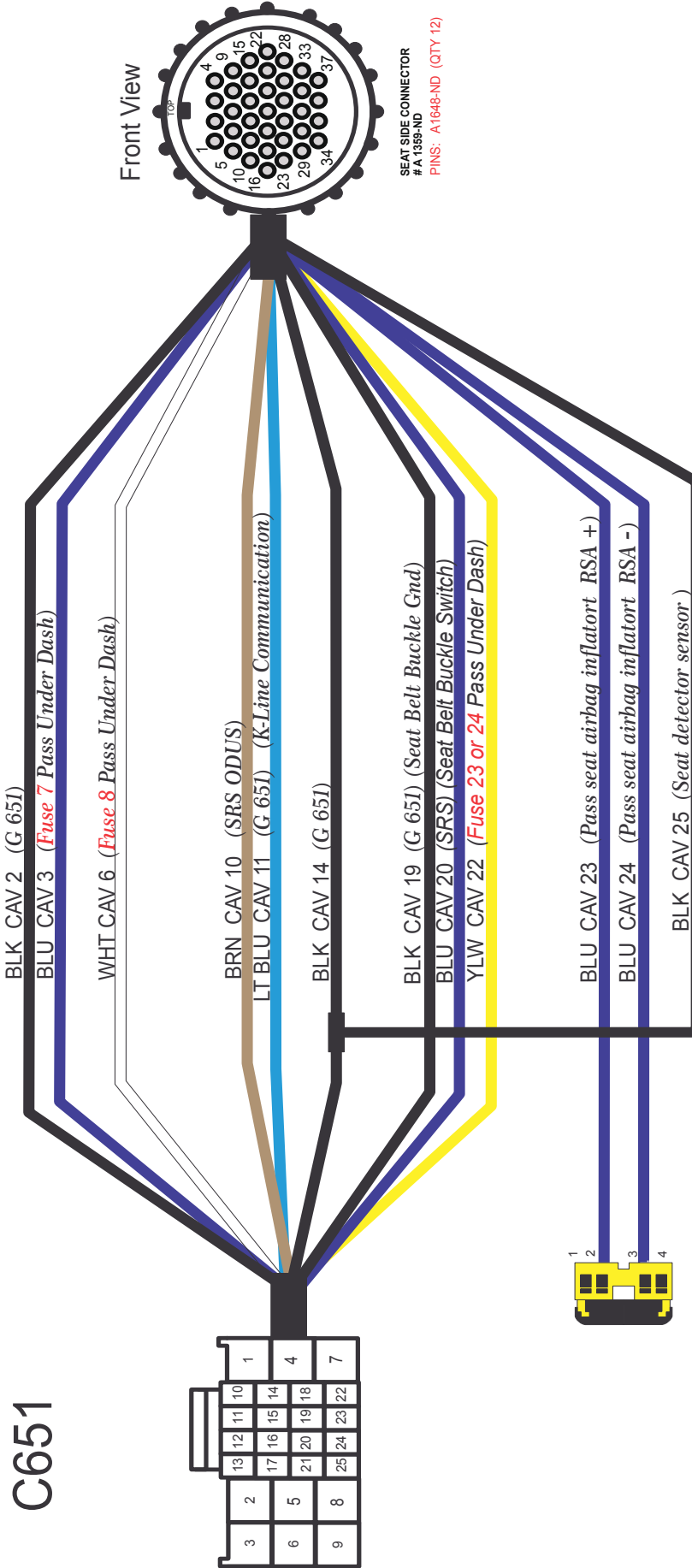



2014-2016 Honda Odyssey Minivan Passenger Seat C651 H.S.M. Relocated Body Side

7/15/2015

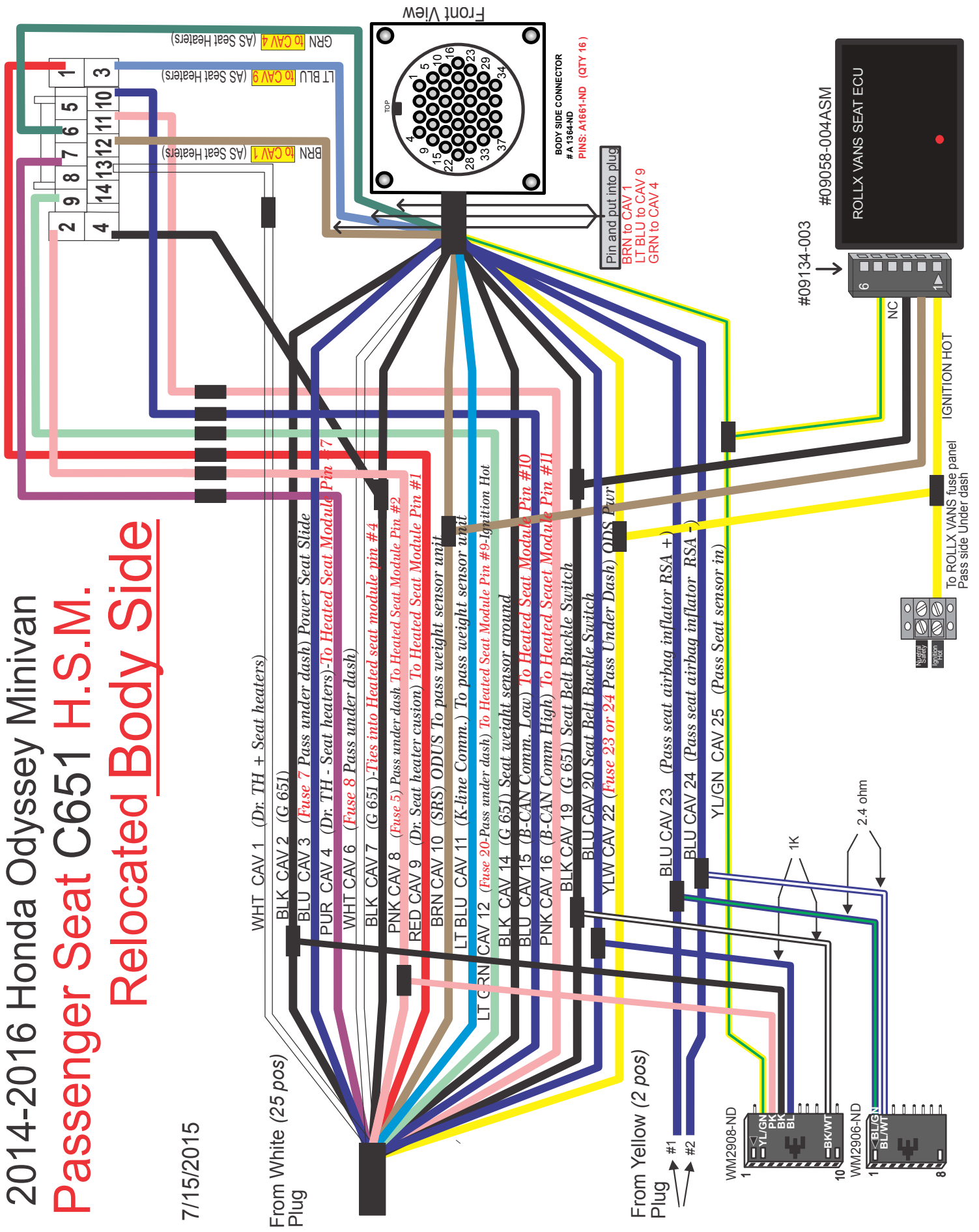



9/21/2015

2014-2016 Honda Odyssey Minivan Passenger Seat C651 H.S.M Relocated Seat Side

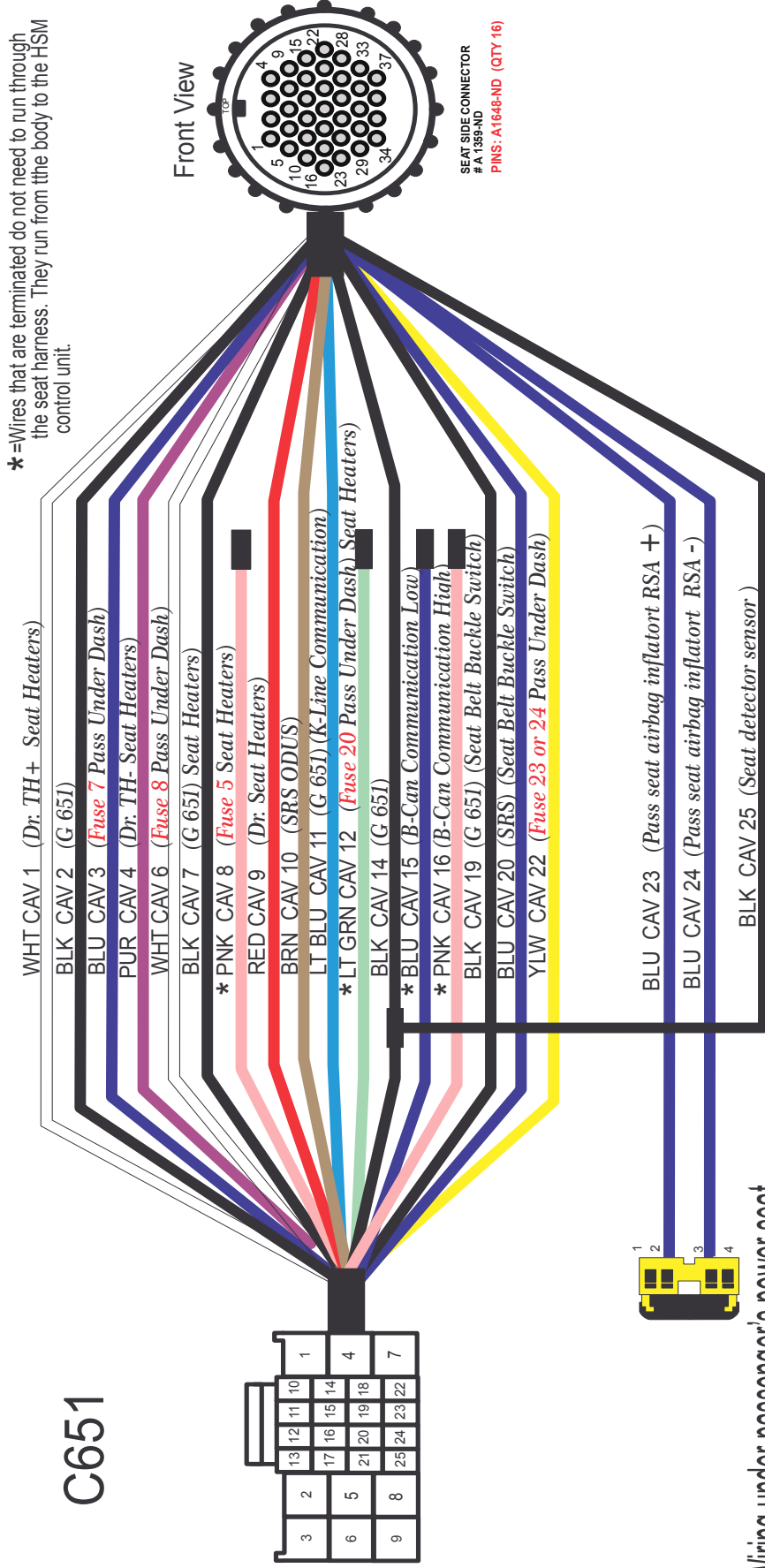

C651

13	12	11	10	1
2	3	4	5	6
17	16	15	14	4
21	20	19	18	7
9	8	25	24	23
22				

Wiring under passenger's power seat



H.S.M. Harness under passenger's seat

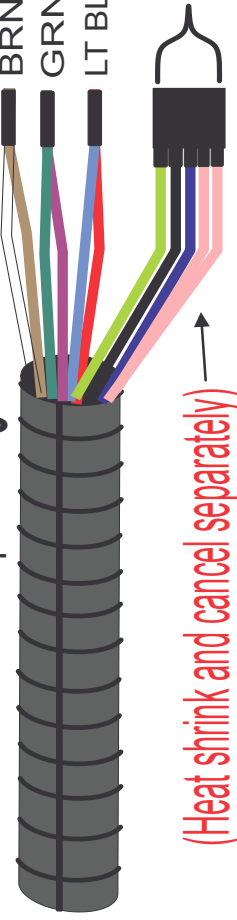

SEAT HEATER PLUG

- OEM CAV 12 & 13
- OEM CAV 6 & 7
- OEM CAV 1 & 3



12/17/2015

2014-2016 Honda Odyssey Minivan

Driver Seat C601 Power No Heat Body Side

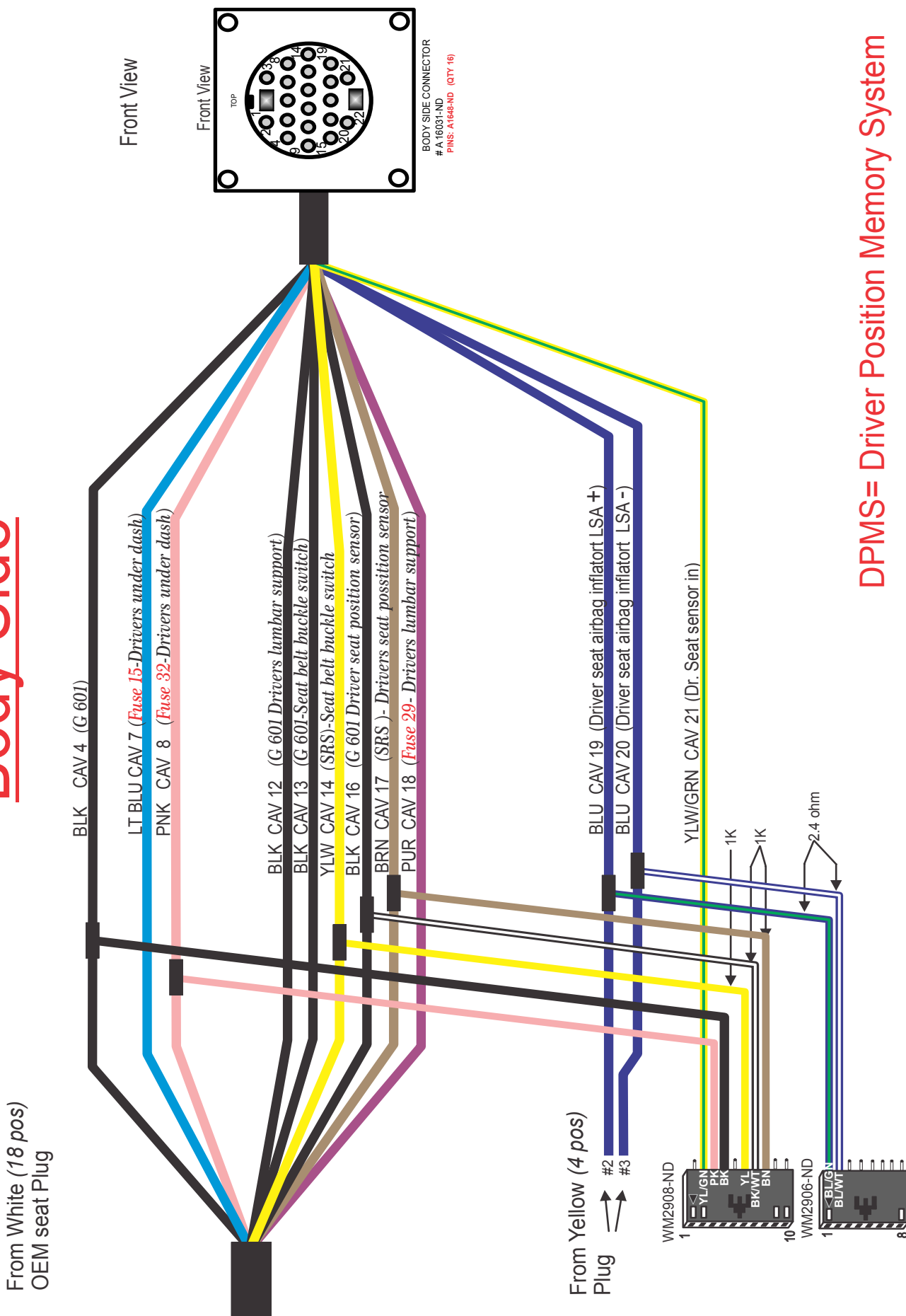

DPMS= Driver Position Memory System

12/17/2015

2014-2016 Honda Odyssey Minivan Driver Seat C601 Power No Heat





7/15/2015

2014-2016 Honda Odyssey Minivan

Driver Seat C601 **NO DPMS W/ Heat**

Body Side

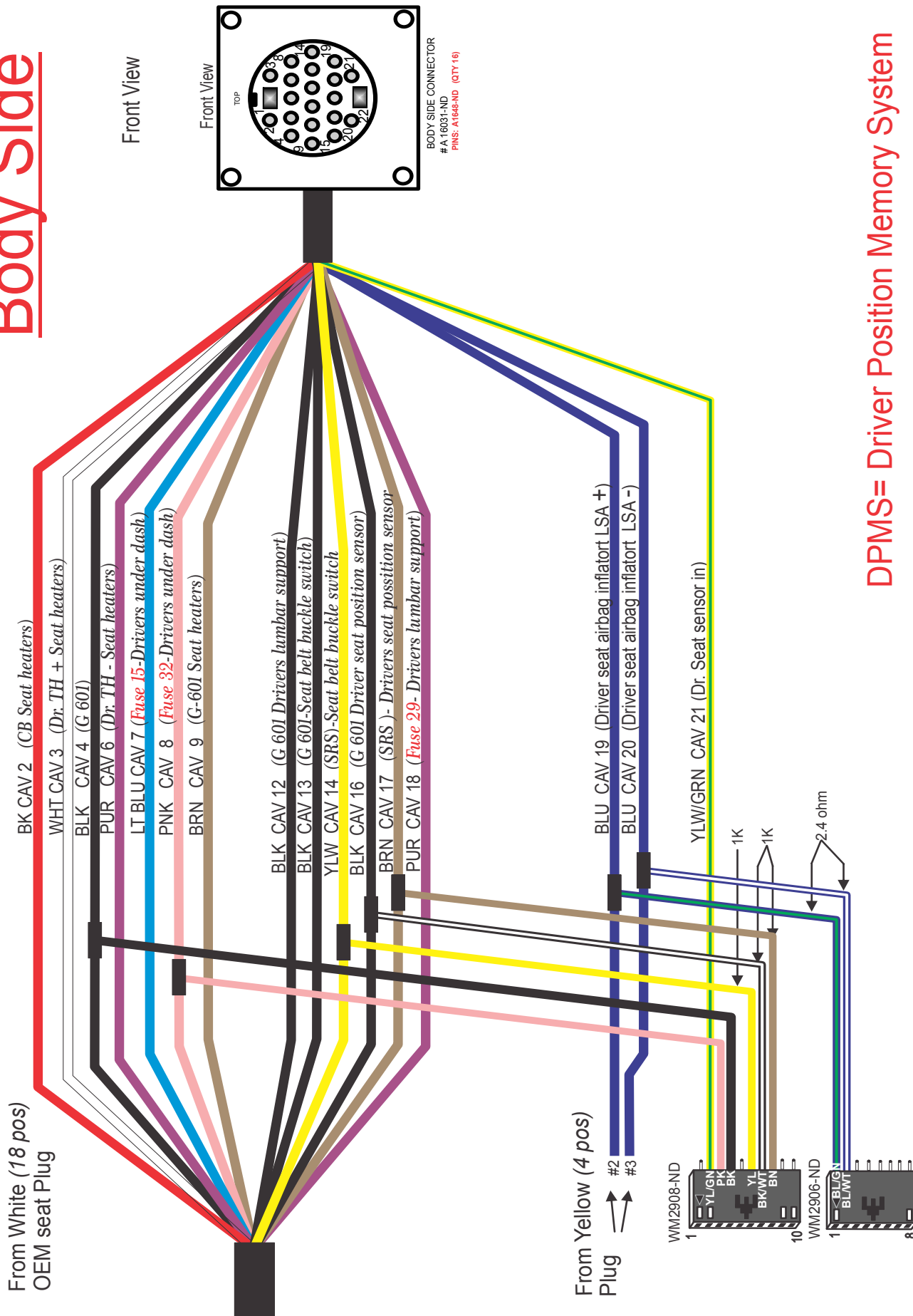

DPMS= Driver Position Memory System

2014-2016 Honda Odyssey Minivan Driver Seat C601 No DPMS W/ Heat

9/21/2015

Seat Side



C601

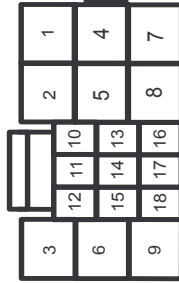

7/15/2015

2014-2016 Honda Odyssey Minivan Driver Seat C601 With DPMS W/ Heat

Body Side

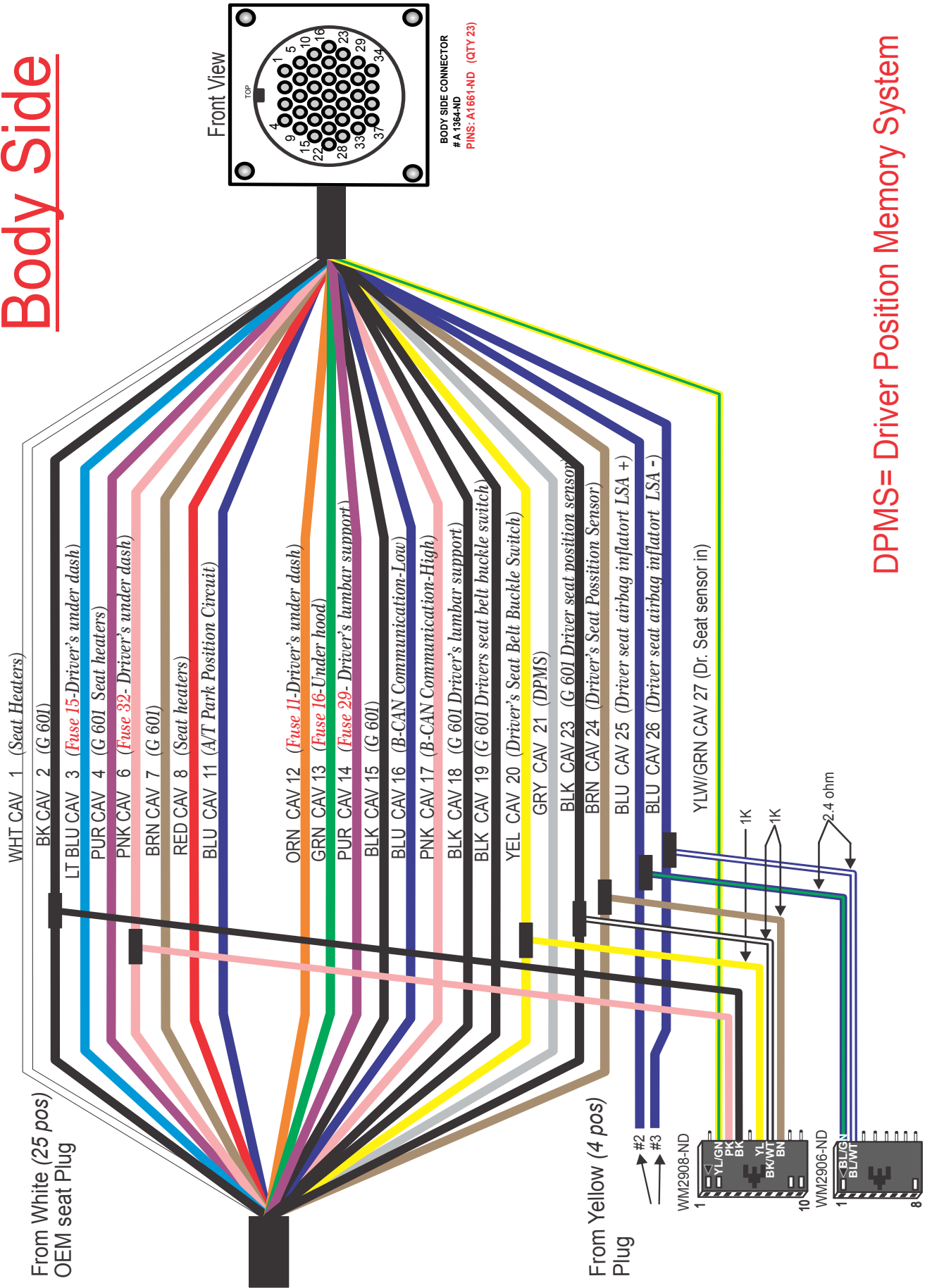

DPMS= Driver Position Memory System

Driver Seat C601 With DPMS W/ Heat Seat Side

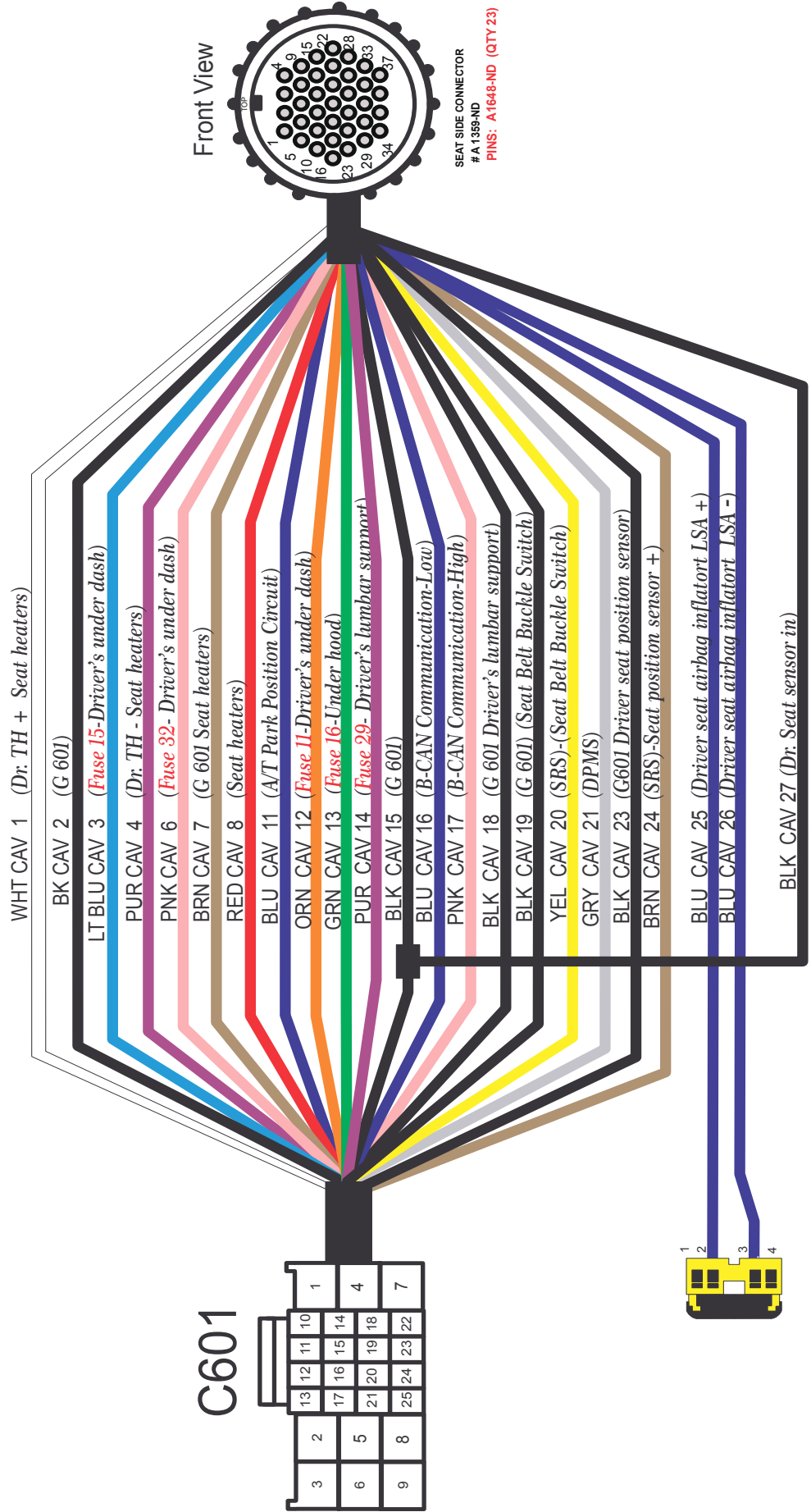

C601

1	2	3	4	5	6	7
8	9	10	11	12	13	14
15	16	17	18	19	20	21
22	23	24	25	26	27	



Rollx Vans Honda Seat ECU V-3.00 MOD C

(See Technical Manual for more information)

Overview

In order to keep OEM operation of the front seats as close to original as possible, Rollx Vans has developed the Rollx Vans Seat ECU. When the front seats are present, they should operate the same as they would before conversion. With either or both front seat removed the Seat ECU becomes active and makes the Honda computer (SRS Controller) think that the seats are still present. When the Honda Seat Detector becomes active it listens to the Honda network communication bus and automatically responds as needed. It presents information to the SRS Controller indicating a full size adult is seated and is sitting in the full up right position in the seat. This action does two things: 1) keeps the SRS Controller from turning on the SRS and Airbag Warning Lights 2) enables the Passenger Seat and Right Side Airbags. It also presents a ground signal signifying that the seat belt is plugged in. The information being sent from the Honda Seat ECU(s) varies from van to van. This means that while the circuitry (Hardware) for the Rollx Vans Seat ECU can be used in any Honda, the program running on it has to change for each van and this is accomplished through the "learn mode."

The Rollx Vans Seat ECU is powered by the Ignition Switch. When the Ignition Switch is on, power is supplied to the Rollx Vans Seat ECU. When the Ignition Switch is turned off, power is removed from the Rollx Vans Seat ECU. The unit does not draw power from the battery when it's off.

Location

Lower Passenger Side B-Pillar

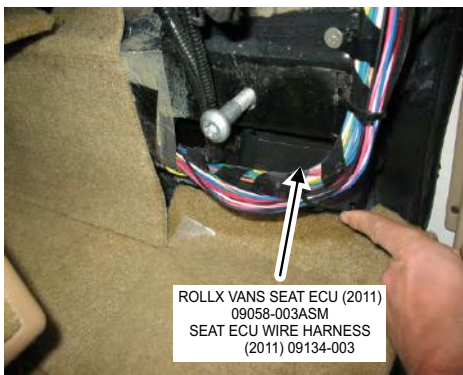

Location

Lower Passenger Side B-Pillar

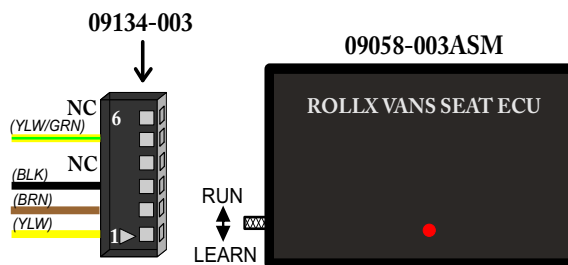

Learn Mode

1. Insure the Ignition Switch is off.
2. Check the seat connector. The seat must be plugged in before you continue.
3. Place the Rollx Vans Seat ECU in Learn Mode.

Locate the Baton (Lever) of the small Slide Switch next to the 6-Way I/O Connector found on the Rollx Vans Seat ECU. The switch has two positions 1) "Run Mode" when the switch Baton is moved to the position closest to the I/O connector. 2) "Learn Mode" when it's moved to the position away from the connector. Move the switch to the "Learn Mode" position.

4. Sit in the Passenger seat.
Note: During the Learn Mode, the weight of the passenger must greater than 70 lbs.
5. Buckle the Passenger Seat Belt.
6. Buckle the Drivers Seat Belt.
Note: You do not need someone sitting in the Drivers Seat during the learn process.

7. Insure you're sitting in the full upright position and not leaning either forward or to the right during the Lean Mode procedure. Do not move around in the seat during the learn process.



Learn Mode (continued)

8. Reach over and turn on the Ignition Switch. **DO NOT START THE VEHICLE!** You should hear the unit beep three times indicating it has started the learn process.

Note: If you hear the unit beep two times over and over again, it means the seat is not properly plugged in. If you hear the double beeping, turn off the Ignition Switch. Install or remove and reinstall the Passenger Seat Connector, then restart the procedure.

Note: If you run the Learn Mode more than once and hear the double beeping, there is a problem with the seat wiring.

Note: The Status LED will show Red and Green during Learn Mode.

9. Observe the SRS and Airbag Status Lights on the Instrument Panel. You should see them both go off after several seconds. Continue to monitor them for at least 30 seconds. If there is a problem it may be possible for them to light back up within the period of time.

10. Check the Passenger Seat Belt Warning Light. It should be off.

11. Continue to sit (without movement) until you hear the Rollx Vans Seat ECU beep four times and/or see the Status LED flash green four times over and over. This indicates the Learn Operation has completed successfully.

Note: If the unit beeps once and the Status LED lights either red or green, the learn process failed. Turn off the Ignition Switch and repeat the process. If the learn process fails a second time, see the Trouble Shooting section below.

12. Turn the Ignition Switch off.

12. Place the Rollx Vans Seat ECU in Run Mode.

Move the Baton (Lever) of the Mode Switch down to the Run Mode position (closest to the 6-Way I/O Connector). Check for correct operation as described below.

Run Mode (Operational Test)

Note: The Learn Mode must be completed successfully before operating the Rollx Vans Seat ECU in the run mode.

Use the follow the step by step procedure to place the Rollx Vans Seat ECU in Run Mode and test its operation.

1. Turn the Ignition Switch off.

2. Insure the unit is in the Run Mode.

Mode Switch is in the "Run Mode" position (Baton moved to the position closest to I/O Connector).

3. Make sure the Passenger Seat is plugged in.

4. Turn the Ignition Switch on.

5. Check the Status LED on the front of the Rollx Vans Seat ECU. It should be green.

6. Watch the Airbag, SRS and Passenger Seat Belt Warning Lights on the Instrument Panel. All three lights should go out after a few seconds and remain off. The Rollx Vans Seat Detector is now idling and the Honda Seat ECU(s) is/are in operation.

7. Turn off the Ignition Switch. Wait for the Instrument Panel Lights to go off before going on.



Run Mode (Operational Test) (continued)

8. Unplug the Passenger Seat Connector.
9. Turn on the Ignition Switch.
10. Check the Status LED on the front of the Rollx Vans Seat ECU, it should be red.
11. Watch the Airbag, SRS and Seat Belt Warning Lights on the Instrument Panel. All three lights should go out after a few seconds and remain off. Watch them for at least thirty seconds. The Rollx Vans Seat ECU is now in operation, responding to requests from the Honda SRS Controller in place of the Honda Seat ECU(s).
12. Test complete, turn off the Ignition Switch.

Status Codes

1. Status LED codes. The operational status of the Rollx Vans Seat ECU can be determined by viewing the state of the Status LEDs during operation.

- A. Status LED off. The Rollx Vans Seat ECU is powered down (off).
- B. Status LED Green. Indicates the unit is in Run Mode with the Honda Passenger Seat installed and connected. The Honda Seat ECU(s) is/are in operation. The Rollx Vans Seat ECU is in Idle Mode.
- C. Status LED Red. The unit is in Run Mode and the Passenger Seat is removed or disconnected. The Rollx Vans Seat ECU is in operation, responding to communications traffic from the SRS Controller.
- D. Status LED both Red and Green. The unit is in Learn Mode.
- E. Status LED flashing Green four times. Used only in Learn Mode. When the Status LED flashes green four times over and over, the Learn Mode has been completed successfully.
- F. Status LED flashes green once. Used only in Learn Mode. When the unit exits Learn Mode without learning, the Status LED flashes once.

2. Beeper Status Codes. Beep codes are only used to indicate the operational status of the Learn Mode. The beep codes are provided to make it easy for a single person to run the Learn Mode. During the Learn Mode, it's important that the person sitting in the Passenger Seat not move around and sit upright. In this position it's difficult to determine the status of the learn operation by viewing the Status LED. For this reason, beep codes have been added to the unit.

- A. Two Beeps. At the start of the Learn Mode, the unit will beep twice if it finds the Honda Passenger Seat is not properly plugged in (required for the Learn Mode).
- B. Three beeps. The Rollx Vans Seat ECU beeps three times when it enters (starts) the Learn Mode.
- C. Four beeps. The Rollx Vans Seat ECU beeps four times when the Learn Mode has completed successfully.
- D. One beep. The unit will beep once if it terminates the learn operation without correctly learning.



Trouble-shooting

NOTE: if available use the Honda Diagnostic System to check for Diagnostic Trouble Codes (DTCs) for the SRS System. These warning lights can be triggered by many potential problems throughout the SRS system. It will simplify the trouble shooting process if you can be sure the problem involves the passenger seat installation. The DTC code will tell you the nature of the problem, giving you an idea where to start your trouble shooting effort.

Note: To use this section of the manual you must be familiar with all the information present in the first three sections of this manual.

Note: Before trouble-Shooting make sure the battery voltage is ok. A simple test is to try and start the vehicle. It should start right up without hesitation. Otherwise, charge the battery before going any farther.

1. Rollx Vans Seat ECU connector signal description

Pin 1: Vehicle Battery Voltage switched by Ignition Switch. (YLW).

Pin 2: Honda Network Communications Bus. (BRN).

Pin 3: Vehicle Ground. (BLK).

Pin 4: Not Used.

Pin 5: Seat Detector Input. (YLW/GRN).

Pin 6: Not Used.

2. Run Mode. The following is a list of possible Run Mode issues with a number of associated corrective actions.

A. Status LED does not illuminate (in any color) when Ignition Switch is turned on.

1. No battery voltage. Use a Multi-meter set on DC Voltage to check for battery voltage on pin 1 of I/O Connector.

2. Missing Ground. Use a Multi-meter set to an Ohms (Continuity) range to check for ground on pin 3 of I/O Connector.

3. Check the appropriate Honda fuse for the Ignition Hot Line used to power the Rollx Vans Seat ECU. Fuse #21 found in the Honda Passenger Seat Under-dash Fuse/Relay Panel.

B. Status LED fails to show green when Passenger Seat is plugged in.

1. Passenger Seat not plugged in or connector not fully seated. Unplug Seat Connector. Inspect for damaged or bent pins. Plug seat in and insure connector (pins) fully seat.

2. Rollx Vans Seat ECU input wire bad. Using a Multi-meter set to measure Ohms, check the Rollx Vans Seat ECU I/O Connector to insure a ground is found on the black wire. Pin 4 on V-1.00 or pin 5 on V-3.00.

3. Insure a jumper wire has been added to the Seat Connector. Found on the Seat Side between ground (Pin 1), and the Seat Detect signal on pin 14.

C. Status LED fails to show red when Honda Passenger Seat is removed.

1. Rollx Vans Seat ECU Seat Detect input wire bad. Disconnect the unit. Use a Multi-meter set to measure ohms (continuity). Check the black wire on the body side connector, pin 4 on V-1.00 or pin 5 V-3.00. If grounded, wire is shorted.



Trouble-shooting (continued)

D. Status LED shows both red and green with or without the Honda Passenger Seat installed.

1. Check the operational mode of the unit. The Status LED lights red and green only in Learn Mode.

Make sure the Baton (Lever) on the Mode Switch is in the Run Mode (down position closest to 6-Way I/O Connector).

E. Seat Belt Warning Light illuminates (Passenger Seat removed, Status LED illuminated red).

1. Drivers Seat Belt not plugged in. Plug it in.
2. Check Rollx Vans Seat ECU, Passenger Seat Belt Latch Output for a failure. Using a Multi-meter set to measure ohms (continuity), check for a ground on Pin 6 of 6-Way (V-3.00) I/O Connector. You should be able to measure a short to near ground (within a few ohms of ground) when Passenger Seat is not installed. When the seat is installed you should not be able to measure a short to near ground on this pin.
3. If either of the above tests fail, unplug the Rollx Vans Seat ECU. On the body side (harness side) connector, ground Pin 6 of 6-Way. The Seat Belt Warning Light should go off. If it does, replace the Rollx Vans Seat ECU. If not, there is a wiring problem. The wire is shorted to ground.

F. SRS and/or System Airbag Warning Light illuminates.

1. Make sure the Rollx Vans Seat ECU has gone through the learn process on this van correctly. If you are unsure, then run the Learn Mode.
2. If the Passenger Seat is installed.

Unplug the Rollx Vans Seat ECU. If the Warning Light(s) remain on the problem is either the Honda ECU(s) or the seat wiring. If the Warning Light(s) go out, replace the Rollx Vans Seat ECU. Don't forget to "Learn" the new unit.

3. Make sure the Rollx Vans Seat ECU is in the Run Mode.

Note: In Run Mode with the Passenger Seat removed, the Status LED lights Red. With the seat installed, the Status LED lights green.

4. Make sure the Passenger Seat Connector has been removed completely, and not just loosened.
5. Check for broken or shorted wires and bent pins on the I/O Connectors connecting the Rollx Vans Seat ECU to the vehicle and the Seat Connector.
6. Check power and ground connects to the Rollx Vans Seat ECU.
 - a. Battery voltage. Use a Multi-meter set on DC Voltage to check for battery voltage between pin 1 (Red meter lead) and 3 (Black meter lead) of I/O Connector.
 - b. Ground. Use a Multi-meter set to Ohms (Continuity) range to check for ground on Pin 3 of I/O Connector. You should find the reading near ground (with in a few ohms).
7. Check the Seat Detector input wire. If the seat is installed, use a Multi-meter set to measure Ohms (continuity). Insure a near ground (with in a few ohms) is present on the black wire, Pin 5. If the seat is not installed, you will not find a short to ground on this signal.



Trouble-shooting (continued)

8. Check the Seat Side of the seat connector. Insure a jumper wire has been added between ground (Pin 1), and Pin 14.

9. Check the Honda Communication Network connections (the GRN/ORG wire). The Rollx Vans Seat ECU sends information to the SRS Controller via this signal. If the signal is bad, it will corrupt this information, causing the SRS Controller to turn on the SRS and/or Airbag Warning Lights. Run the following checks on this signal:

Note: for the following checks, unplug the I/O Connector from the Rollx Vans Seat ECU.

Note: The checks should be done on the Body-side Connector. Not on the connector found on the Rollx Vans Seat ECU.

a. Use a Multi-meter set to Ohms (Continuity) range to check for a ground on Pin 2 of I/O Connector. The reading should not be near ground.

b. Disconnect the Ground Cable from the vehicle battery. Use a Multi-meter set to Ohms (Continuity) range. Check continuity between Pin 1 and 2 of I/O Connector.

3. Learn Mode.

A. No beeps are heard when Ignition Switch is turned on.

1. Make sure the Rollx Vans Seat ECU is in the Learn Mode. Note: in Learn Mode the Status LED should light red and green.

2. Check power and ground connects to the Rollx Vans Seat ECU.

a. Battery voltage. Use a Multi-meter set on DC Voltage to check for battery voltage between pin 1 (Red meter lead) and 3 (Black meter lead) of I/O Connector.

b. Ground. Use a Multi-meter set to Ohms (Continuity) range to check for vehicle ground pin 3 of I/O Connector. You should find the reading near ground (with in a few ohms).

c. Check the Honda fuse for the Ignition Hot Line used to power the Rollx Vans Seat ECU. Fuse #21 found in the Honda Passenger Seat Under-dash Fuse/Relay Panel.

B. Status LED(s) fail to light both red and green when the Ignition Switch is turned on.

1. Perform the same checks found in item A above.

C. ECU Beeps twice over and over when placed in Learn Mode.

1. While in the Learn Mode, the Rollx Vans Seat ECU beeps twice repeatedly when it fails to see the "Seat Detect" signal.

This signal is a ground signal placed on Pin 5 on the 6-Way I/O Connector when the seat is plugged in.

The signal is generated by the Seat Connector on the Seat-Side. A Jumper is run between the Ground found on pin 1 and the "Seat Detect" signal on pin 14.

Use a Multi-meter set to Ohms (Continuity) range and check for continuity between ground and Pin 5 (V-3.00). The ground should be there when the seat is plugged in and disappear when the seat is removed.



Trouble-shooting (continued)

D. Status LED lights red when trying to run the Learn Mode operation.

1. The Rollx Vans Seat ECU is still in Run Mode.

E. Status LED lights green when attempting to run the Learn Mode operation.

1. The Rollx Vans Seat ECU is still in Run Mode.

F. ECU Beeps once during Learn Mode operation.

1. The Rollx Vans Seat ECU will beep once if it fails the Learn Mode. This type of failure is generally caused by corrupt communications on the Honda Communications Network. There are a number of things that can cause this type of corruption.

Note: Because we want to check the Honda Communications Network wiring, the checks should be done on the Body-side Connector with the Rollx Vans Seat ECU unplugged.

WARNING! Turn the Ignition Switch off to remove power from the Rollx Vans Seat ECU wiring while making these measurements.

- a. Use a Multi-meter set to Ohms (Continuity) range. Check for a short between pins 2 & 3 of I/O Connector mate. If you find the reading near ground (within a few ohms), the Honda Communications Network is shorted to ground.

- b. Use a Multi-meter set to Ohms (Continuity) range. Check continuity between pin 1 and 2 of the I/O Connector mate. There should not be a short between these two signals. It should be a high resistance reading (K ohms minimum). If you find a low reading (with in a few ohms of zero), the network communications line is shorted to the battery.

2. Another issue that can corrupt a communications networks is the loss of a good ground connection to the electronics circuits. Run the following test to check the Rollx Vans Seat ECU ground connection.

Note: Because we want to check the ground for the Rollx Vans Seat ECU, the check must be done on the connector found on the Rollx Vans Seat ECU. The unit must be plugged in to its mating connector(s).

WARNING! Turn the Ignition Switch off to remove power from the Rollx Vans seat ECU while making these measurements.

- a. Use a Multi-meter set to an Ohms (Continuity) range. Make a measurement between a known Van "Ground Star Point" and Pin 3 of the Rollx Vans Seat ECU I/O Connector. You should find the reading near ground (with in a few ohms).

G. SRS and/or Airbag Warning Lights fail to extinguish during Learn Mode operation.

1. Unplug the Rollx Vans Seat ECU. If the Warning Light(s) remain on the problem is either the Honda ECU(s) or the seat wiring. If the Warning Light(s) go out, replace the Rollx Vans Seat ECU. Don't forget to "Learn" the new unit.

2. Turn off the Ignition switch.

3. Check for broken or shorted wires and bent pins on the I/O Connectors connecting the Rollx Vans Seat ECU to the vehicle and the Seat Connector.



Trouble-shooting (continued)

4. Check power and ground connects to the Rollx Vans Seat ECU.

a. Battery voltage. Use a Multi-meter set on DC Voltage to check for battery voltage between Pin 1 (Red meter lead) and 3 (Black meter lead) of I/O Connector.

b. Ground. Use a Multi-meter set to Ohms (Continuity) range to check for ground on Pin 3 of I/O Connector. You should find the reading near ground (with in a few ohms).

5. Check the Honda Communication Network connections (the GRN/ORG wire on both versions).

Note: Unplug the Rollx Vans Seat ECU I/O Connector (4-Way for V-1.00, 6-Way for V-3.00).

Note: The checks should be done on the Body-side Connector. Not on the connector found on the Rollx Vans Seat ECU.

a. Use a Multi-meter set to Ohms (Continuity) range to check for a ground on Pin 2 of I/O Connector. The reading should not be near ground.

b. Disconnect the Ground Cable from the vehicle battery. Use a Multi-meter set to Ohms (Continuity) range. Check continuity between Pin 1 and 2 of I/O Connector.

H. Seat Belt Warning Light fails to extinguish during Learn Mode Operation.

1. Drivers Seat Belt not plugged in. Plug it in.

2. Check the Seat Detector input wire. Use a Multi-meter set to measure Ohms (continuity). Insure a near ground (with in a few ohms) is present on the black wire, Pin 5.

ROLLX VANS ONE TOUCH OTC VERSION HONDA 8.00 M

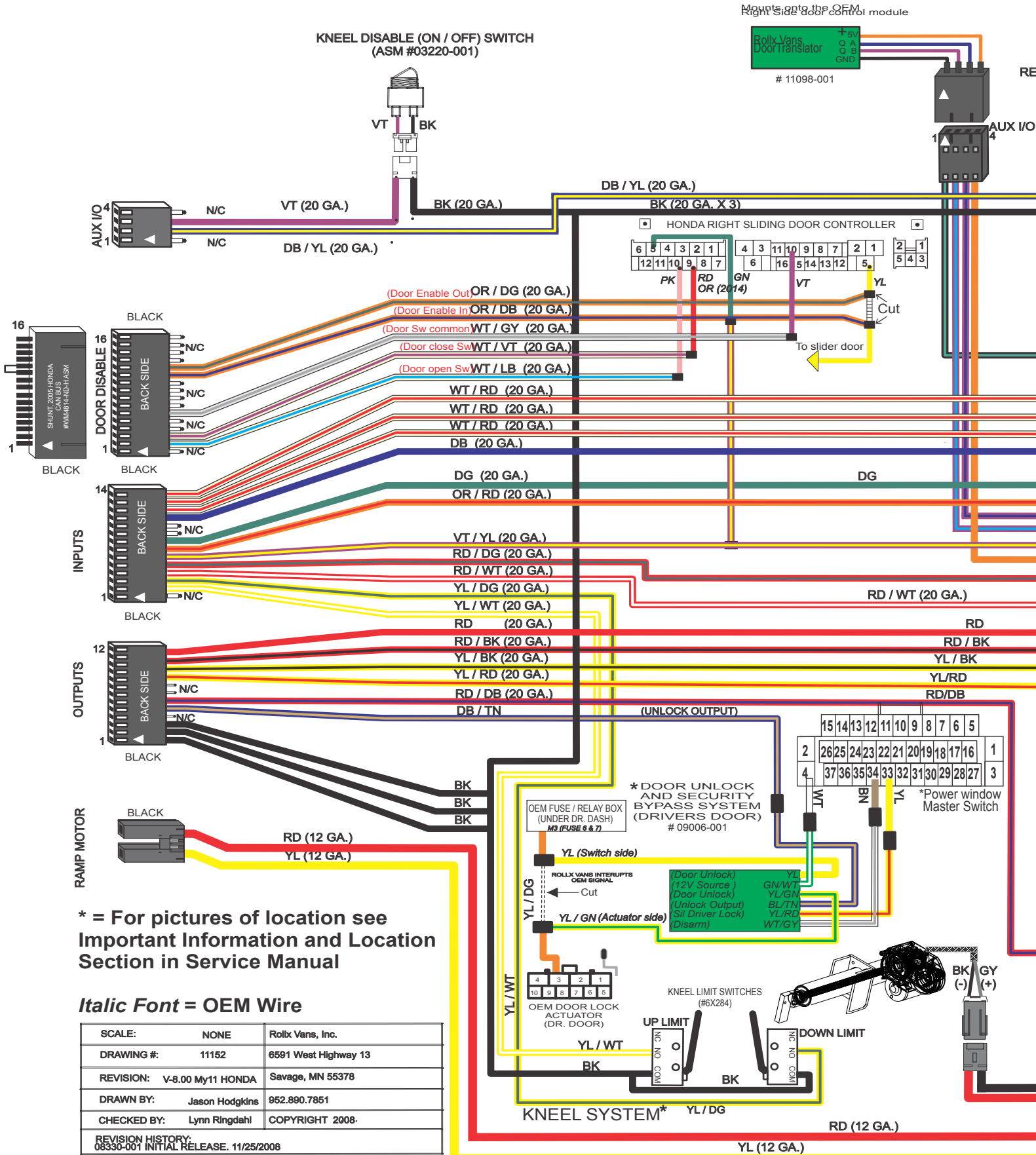

* = For pictures of location see Important Information and Location Section in Service Manual

Italic Font = OEM Wire

SCALE:	NONE	Rollx Vans, Inc.
DRAWING #:	11152	6591 West Highway 13
REVISION:	V-8.00 My11 HONDA	Savage, MN 55378
DRAWN BY:	Jason Hodgkins	952.890.7851
CHECKED BY:	Lynn Ringdahl	COPYRIGHT 2008.
REVISION HISTORY: 08330-001 INITIAL RELEASE. 11/25/2008		

2/26/14

CONTROLLER WIRING DIAGRAM MOD C (2014 Honda Model Year)

Compustar Remote

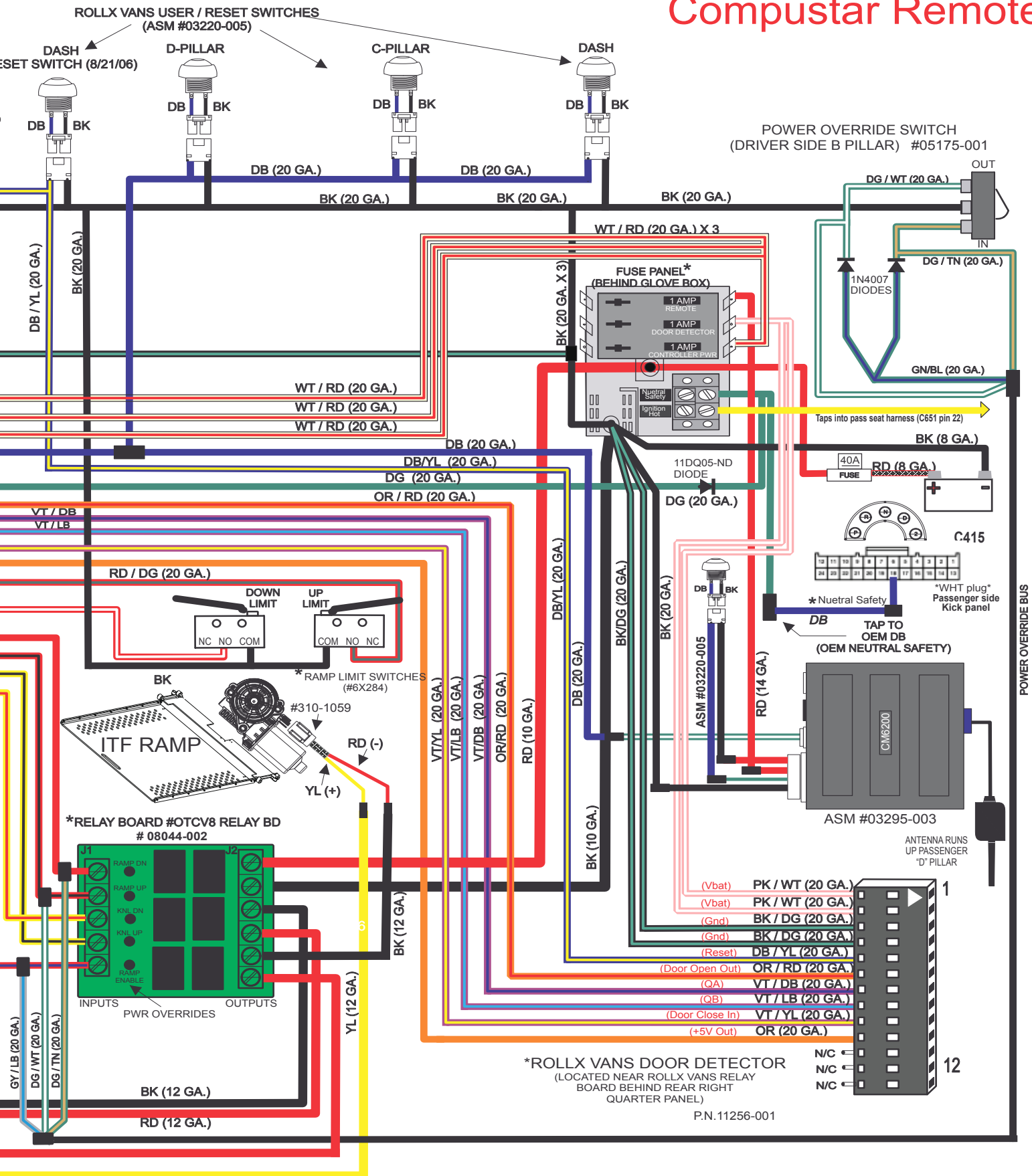

ROLLX VANS ONE TOUCH CONTROL OTC VERSION HONDA 8.00

Removed Door Disable Function

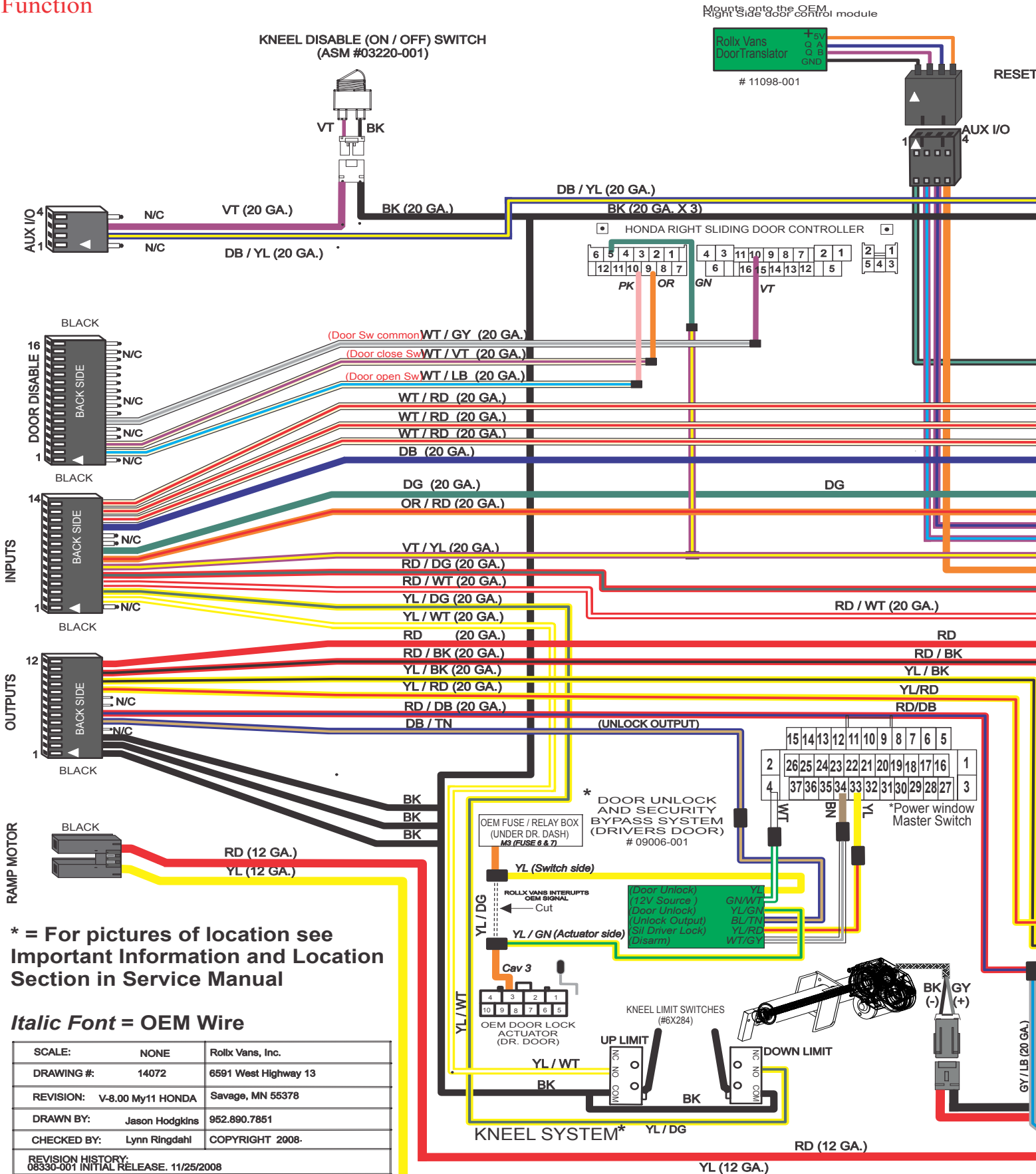

* = For pictures of location see Important Information and Location Section in Service Manual

Italic Font = OEM Wire

SCALE:	NONE	Rollx Vans, Inc.
DRAWING #:	14072	6591 West Highway 13
REVISION:	V-8.00 My11 HONDA	Savage, MN 55378
DRAWN BY:	Jason Hodgkins	952.890.7851
CHECKED BY:	Lynn Ringdahl	COPYRIGHT 2008.
REVISION HISTORY:	08330-001 INITIAL RELEASE. 11/25/2008	

CONTROLLER WIRING DIAGRAM MOD C (2014 Honda Model Year)

Built Between: 3/13/2014
3/17/2014 - 6/8/2015
Compustar Remote

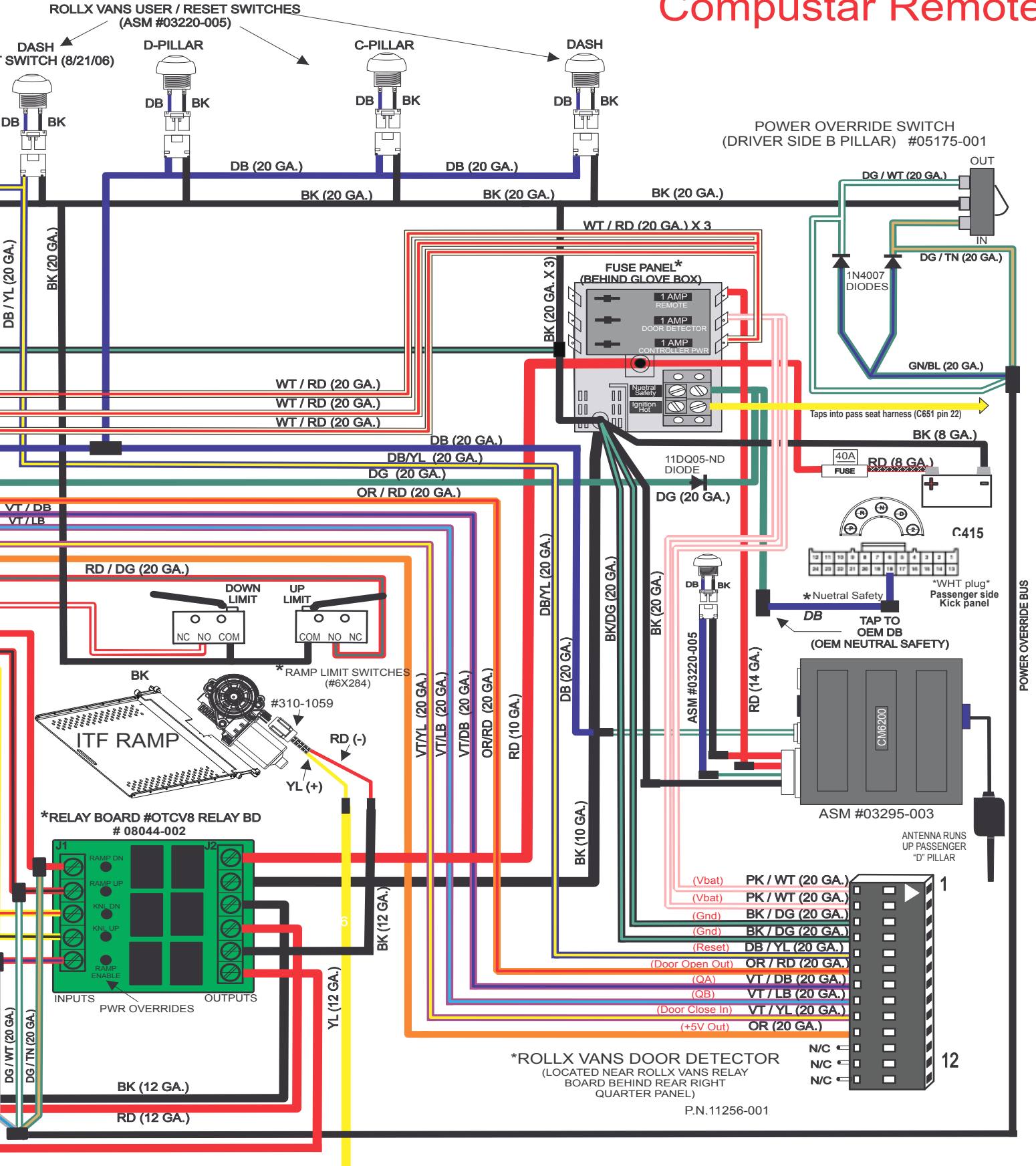

ROLLX VANS ONE TOUCH OTC VERSION HONDA 8.00 MO

Reinstated Door Disable Function

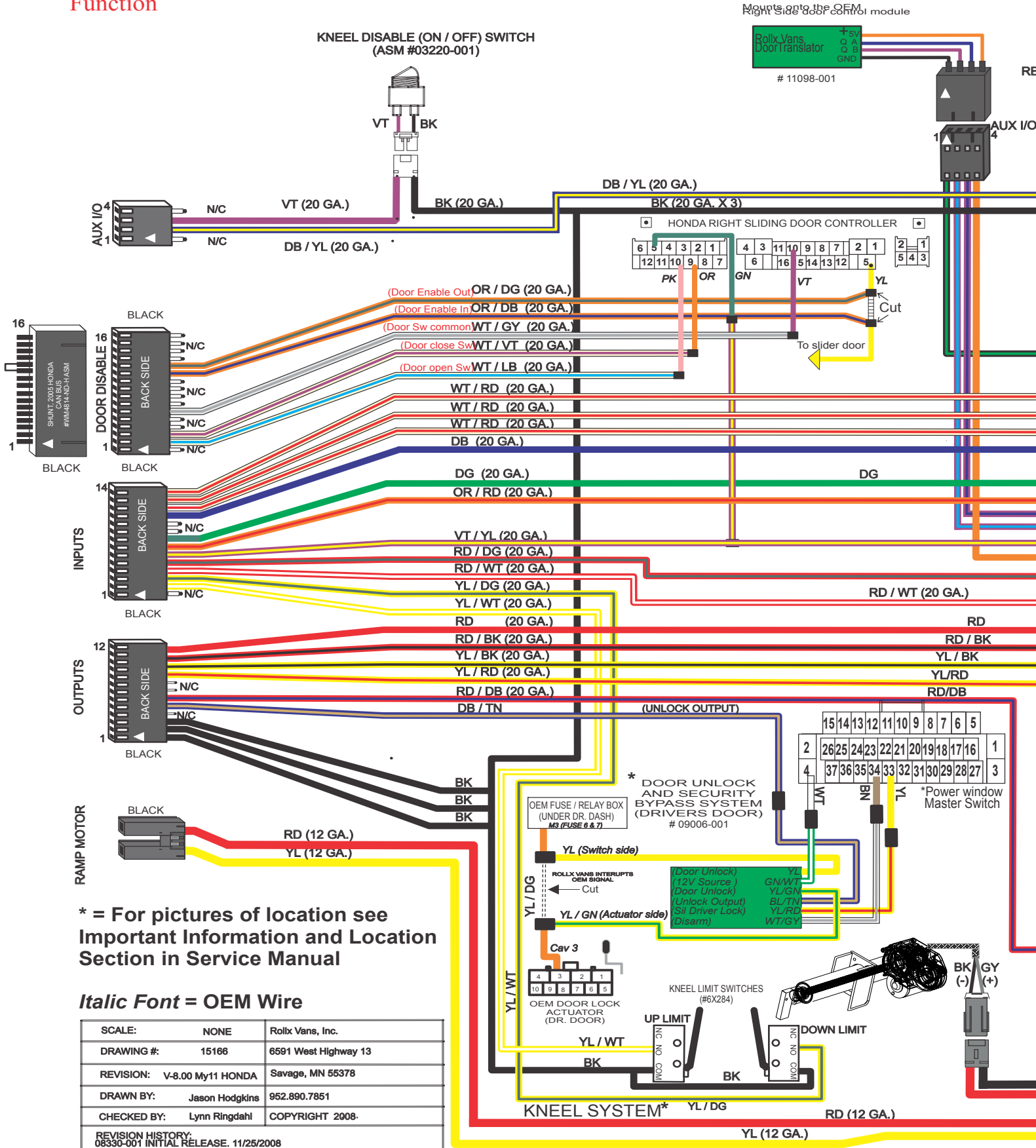

* = For pictures of location see Important Information and Location Section in Service Manual

Italic Font = OEM Wire

SCALE:	NONE	Rollx Vans, Inc.
DRAWING #:	15166	6591 West Highway 13
REVISION:	V-8.00 My11 HONDA	Savage, MN 55378
DRAWN BY:	Jason Hodgkins	952.890.7851
CHECKED BY:	Lynn Ringdahl	COPYRIGHT 2008-
REVISION HISTORY:	08330-001 INITIAL RELEASE. 11/25/2008	

CONTROLLER WIRING DIAGRAM MODEL C (2014 - 2016 Honda Model Year)

Built After: 1/6/16
6/8/2015

Compustar Remote *With Flashing Lights*

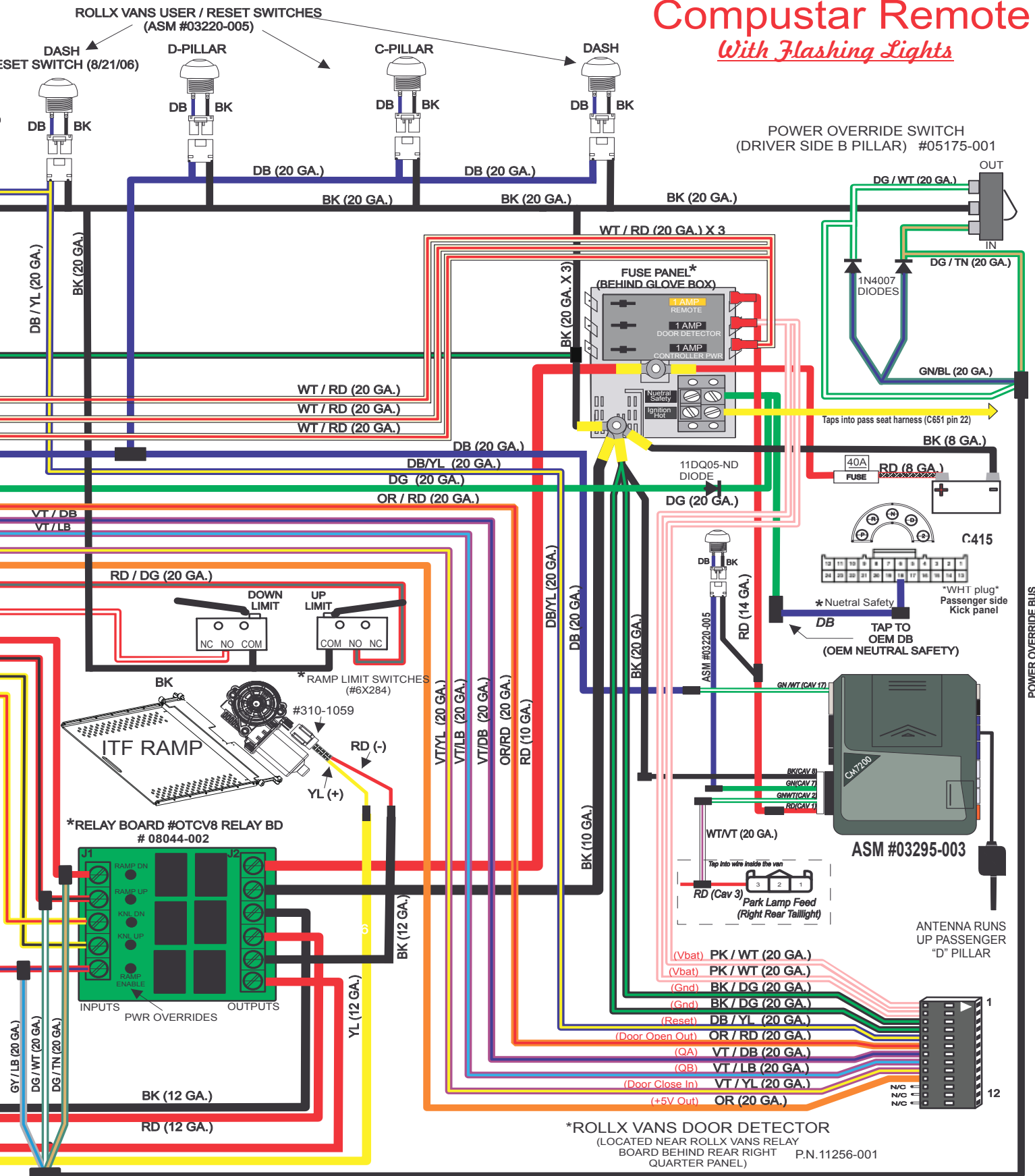

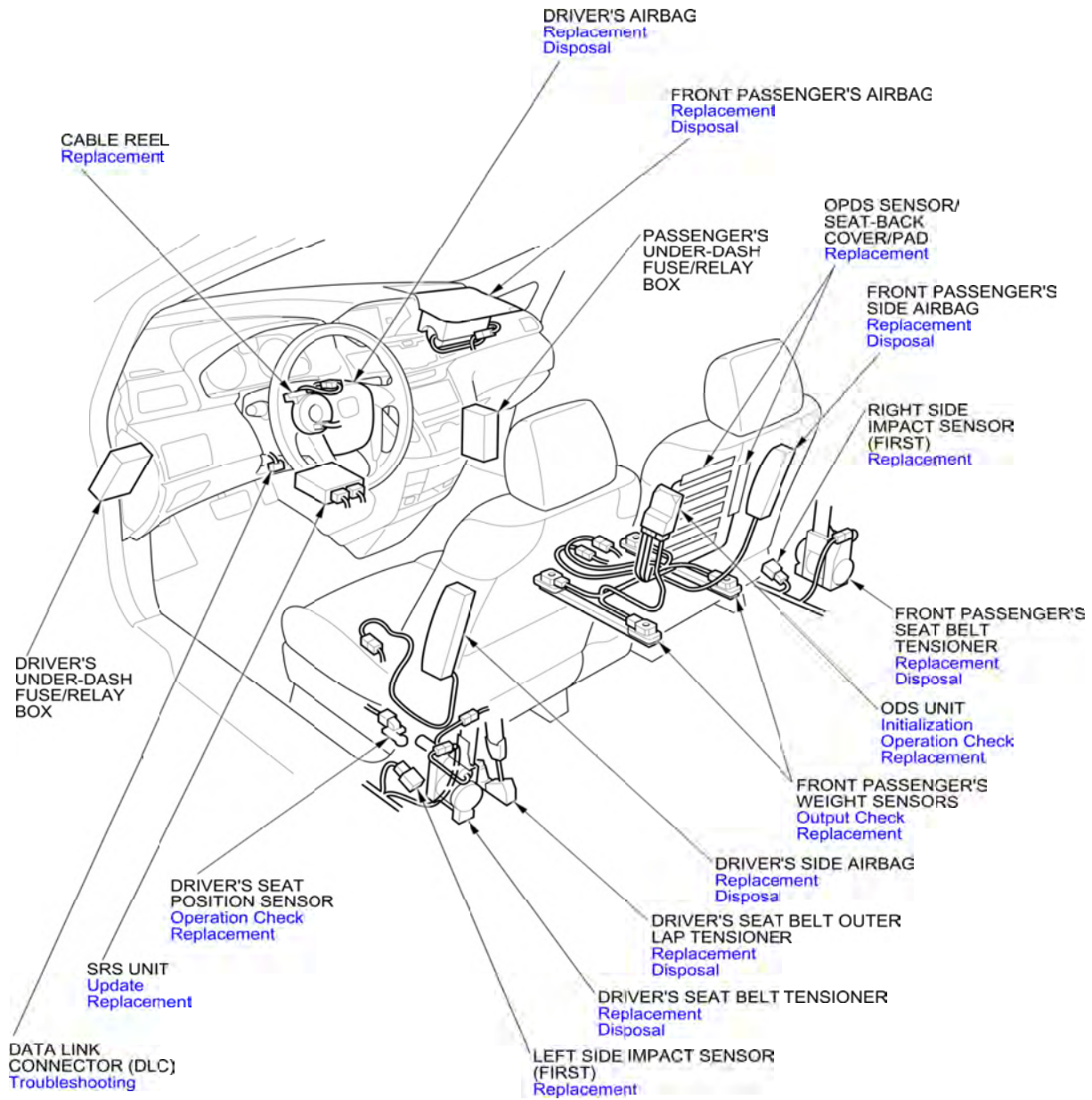

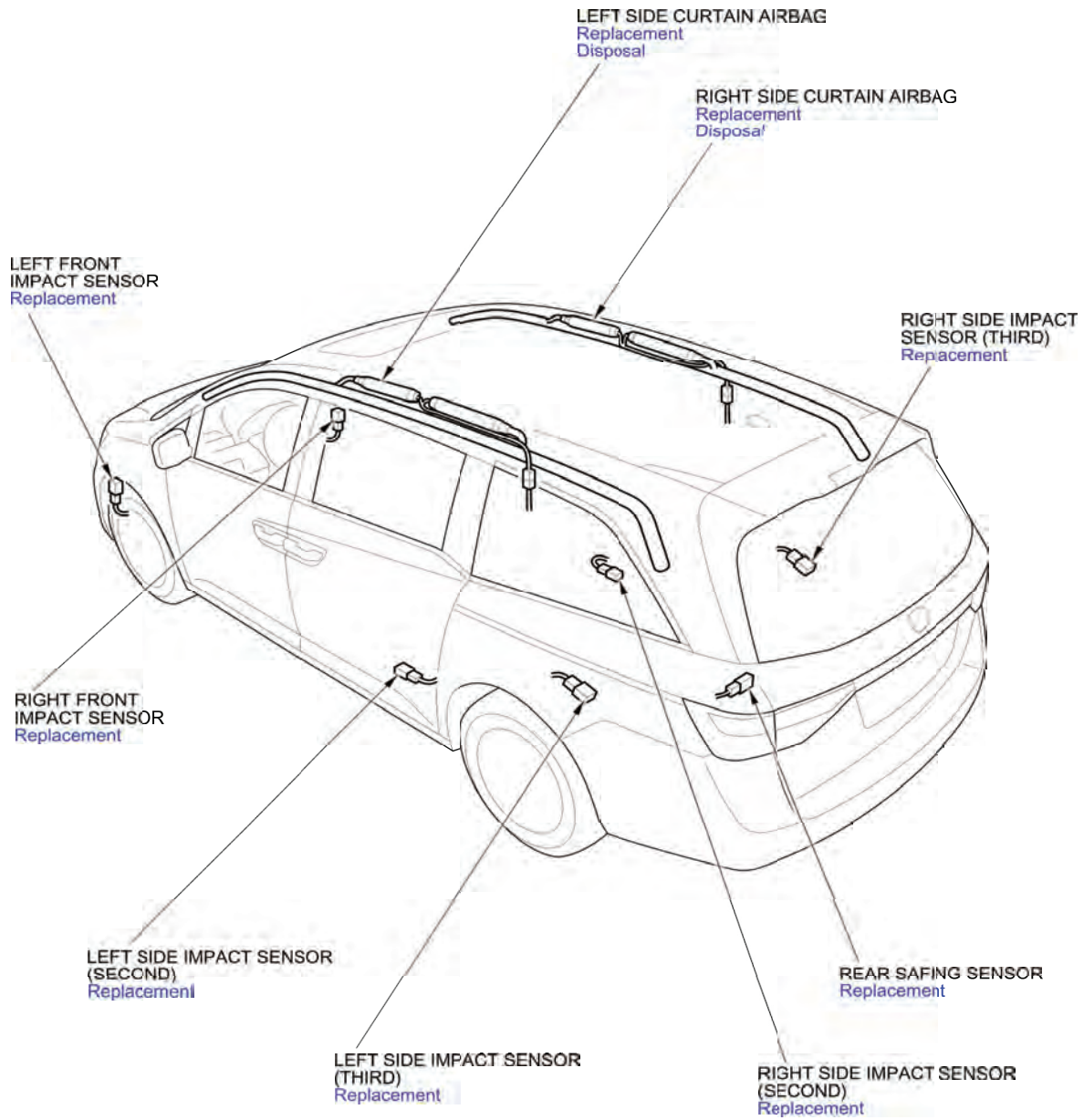

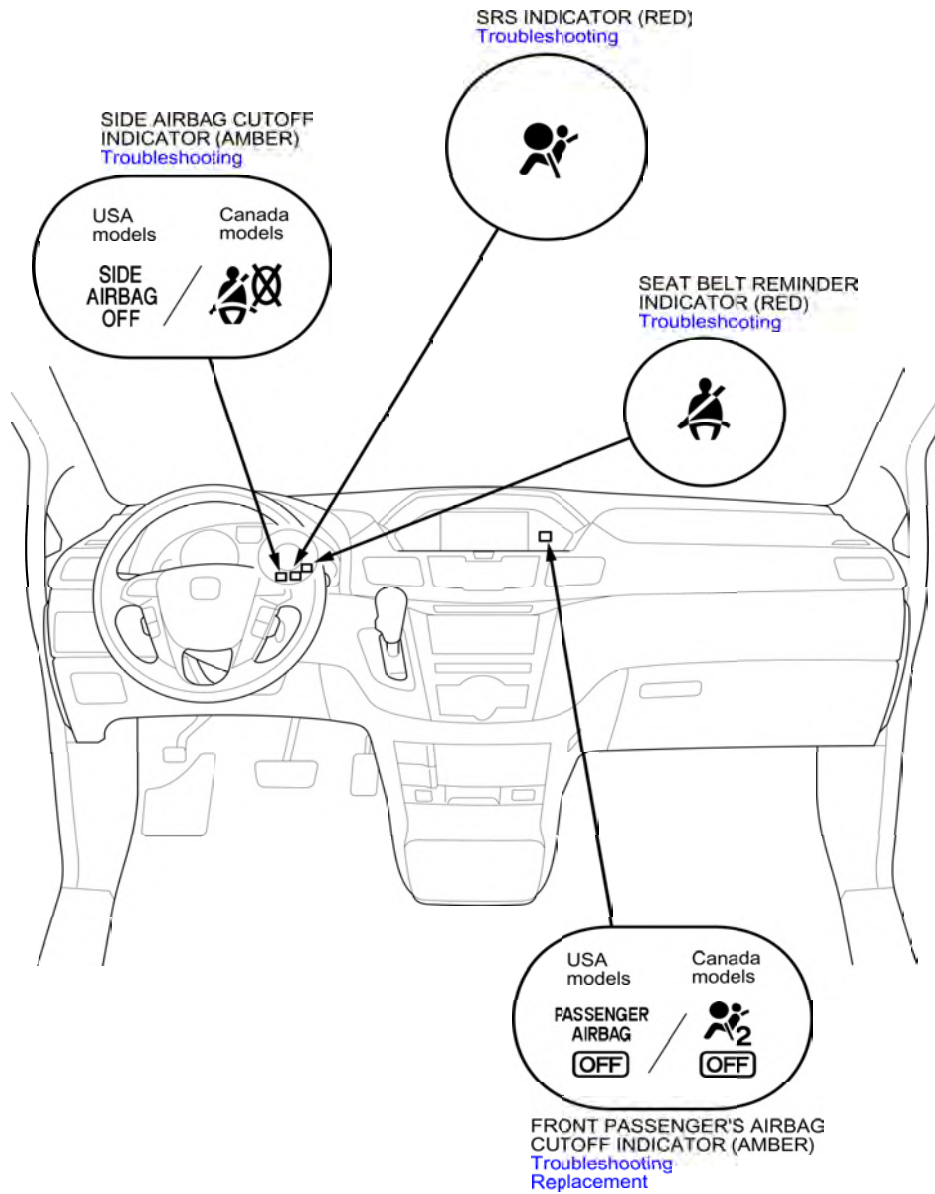



Fuse/Relay Boxes & Ground Locations

**Pass. Under Hood
Fuse/Relay Box**



**Pass. Under Dash
Fuse/Relay Box**



*** B-Pillar
GND**

**Main Under Hood
Fuse Box**

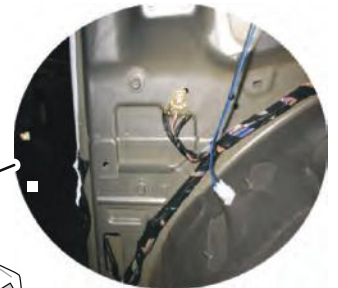

**C-Pillar
GND**



**Dr. Under Dash
Fuse/Relay Box**



*** B-Pillar
GND**

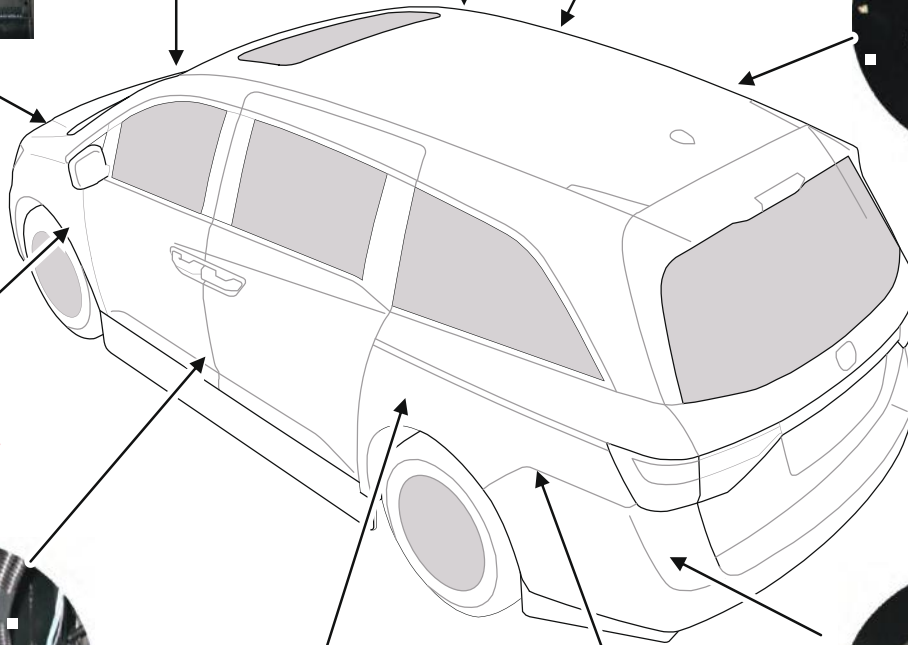

**D-Pillar
GND**



**C-Pillar
GND**



Rear Fuse Box

*** = Relocated**



Doors

Door track - Periodically make sure lower door track is free of debris and vacuum track out. Make certain to clear out any water and ice that may be present. In the front of each door track there are plugs that can be removed to allow an air hose to be inserted to help remove debris.

Kneel System

Kneel chain - Every 6 months spray the chain inside the rubber boot with a high quality oil to lubricate and protect. DO NOT USE WD40.

Ramps

In The Floor ramp - Every 6 months spray the ramp access cover's flap hinge with a high quality silicon lubricant. Also spray the two silver strips on the underside of the ramp to reduce friction.



New Rollx Vans Warranty Coverage Information

Rollx Vans provides a limited warranty on its new conversion minivan against defects in material or workmanship for a period of 3 years or 36,000 miles, whichever comes first. For warranty specifics please refer to an Owner's Manual or contact Rollx Vans Customer Service.

For all warranty or reimbursement needs, you must have prior authorization by the Rollx Vans Service Department.

1. Call 1-800-956-6668, and a Rollx Vans Customer Service Representative will assist you in any concerns or issues you have with your van.
2. The service representative will evaluate what repair is needed, and either set up an appointment with an "At Home" Service Technician or direct you to a nearby service facility. An authorization number must be issued.

Rollx Vans will work with many repair facilities. Rollx Vans reserves the right to approve a repair shop or recommend an alternative.

Rollx Vans may request that defective parts be returned to our Customer Service Department for inspection. If defective parts are found to be defective because of abuse or neglect, reimbursement for the new replacement parts may be denied. Rollx Vans reserves the right to use rebuilt components.

Rollx Vans will ship all warranted replacement parts by nationwide carrier. In most cases, shipment will be by ground transport and absorbed by Rollx Vans. Any other mode of transportation will be at the expense of the customer.

Our Mission

To improve the quality of life of people with disabilities of all income levels by delivering the best modified vehicle.

We intend to keep that customer for life by following up with a level of service that exceeds all of their expectations.

Our Values

Quality • Compassion • Honesty • Integrity • Fairness

